



B/W CCD Camera

Model CS8560D

Specifications

(Ver.1.0)

Contents

1. Product Description	6
2. Features.....	6
3. Configuration.....	7
4. Option Unit.....	7
5. Operation Mode.....	7
6. Specifications.....	24
7. Timing Chart.....	32
8. External View Drawing	40

TOSHIBA TELI CORPORATION



Important Safety Precautions

BEFORE USE - GENERAL SAFETY INSTRUCTIONS

This specifications contains important information for the operator (user) and/or people in the vicinity to avoid personal injury, or property damage.

- Prior to use, read this specifications carefully to fully understand its instructions for correct use.
- After reading, keep operation manual near the equipment for future reference.



WARNINGS & CAUTIONS

Indication	Meaning
 WARNING	This indicates the existence of a hazard that death or catastrophic bodily injury(*1) may result from improper use.
 CAUTION	This indicates the existence of a hazard that bodily injury(*2) or property damage(*3) may result from improper use.

Notes



- *1 Catastrophic bodily injury means loss of eyesight, burns (high and low temperature), shock, fracture, poisoning, etc. which leaves a sequela and require hospitalization or prolonged treatment.
- *2 Bodily injury means injuries, burns and electric shock which does not require hospitalization or prolonged treatment.
- *3 Property damage means extended harm to home, household effects, domesticated animals, and pets.

Graphic symbol definitions

Indication	Meaning
	This mark indicates a prohibited action that must not be carried out. The actual prohibited action is indicated in the symbol or nearby graphically or described in text.
	This mark indicates a mandatory action that must not be carried out. The actual instruction is indicated in the symbol or nearby graphically or described in text.

Handling Precautions

WARNING

	<u>Stop operation immediately when any abnormality or defect occurs.</u> Use during an abnormal condition; such as emitting smoke, burning odors, damage from dropping invasion of foreign objects, etc. may cause fire and/or electric shock. Be always sure to disconnect the power plug from the electrical outlet (socket) at once and contact your dealer.
	<u>Do not operate in places with possibility of becoming wet.</u> This may cause fire and/or electric shock.
	<u>Do not repair, disassemble and/or modify by yourself.</u> This may cause fire and/or electric shock. Be always sure to contact your dealer for internal repair, check and cleaning of the product.



Don't place things or materials on the unit.

Ingress of foreign materials such as metallic things and liquid into the unit may cause a fire or an electric shock.



Do not put the product in an unstable, slanting and/or vibrated place.

Drop and/or fail of the product may cause injury.



Do not touch the power cord or other connection cables during a thunderstorm.

This might cause electric shock.



Use the specified power supply.

Use of an unspecified power supply may result in fire or electric shock.



Do not be handled roughly, damaged, fabricated, bent forcefully, pulled, twisted, bundled, placed under heavy objects or heated the power cord, connection cable.

Otherwise, fire or electric shock may result.

 **CAUTION**

Note the following instructions when installing.



-Do not wrap the product in an inflammable material, such as cloth.

-Do not put the product in a narrow space, since the heat generated from the product may be difficult to emanate.

If you do not follow the above, the heat generated by the product may cause fire.



Avoid setting in humid, smoky, vaporized or dusty places. A fire or an electric shock may occur in such places.

This may cause fire and/or electric shock.



Do not put the product in direct sunshine and/or high temperature.

The temperature inside the product may cause fire.



Use the specified DC power cable or connection cable.

Otherwise, a fire or an electric shock may occur.



Turn OFF the power in the case of connection.

Turn OFF the power in the case of connection of power cable or connection cable.

Otherwise, an electric shock or a malfunction may occur.



Do not expose its camera head to any intensive light (such as direct sunlight).

Otherwise, its inner image pickup device might get damaged.



Avoid short-circuiting signal output.

Otherwise, a malfunction may occur.

Avoid giving a strong shock against the camera body.

It might cause a breakdown or damage.



If your camera is used in a system where its camera connector is subjected to strong repetitive shocks, its camera connector is possible to break down. If you intend to use your camera in such a situation, if possible, bundle and fix a camera cable in the place near the camera, and do not transmit a shock to the camera connector.



Ask your dealer to perform a periodical check and internal cleaning (approx. once every five years).

Dust inside the product may cause fire and/or trouble. For check and cleaning cost, please consult your dealer.

DISCLAIMER (LIMITED WARRANTY)

We disclaim any responsibility and shall be held harmless for any damages or losses incurred by the user in any of the following cases;

- Fire, earthquake or any other act of God; acts by third parties; misuse by the user, whether intentional or accidental; use under extreme operating conditions.
- Malfunction or non-function resulting in indirect, additional or consequential damages, including but not limited to loss of expected income and suspension of business activities.
- Inconvenient use not in compliance with instructions in this instruction specifications and manual.
- Malfunctions resulting from misconnection to other equipment.
- Repairs or modifications made by the user or caused to be made by the user and carried out by an unauthorized third party.
- Notwithstanding the foregoing, Teli's liabilities shall not, in any circumstances, exceed the purchase price of the product.
- About the item which does not have a publication in the specifications and manual of this product, it considers as the outside for a guarantee.

RESTRICTION FOR USE

- Should the equipment be used in the following conditions or environments, give consideration to safety measures and inform us of such usage:
 1. Use of the equipment in the conditions or environment contrary to those specified, or use outdoors.
 2. Use of the equipment in applications expected to cause potential hazard to people or property, which require special safety measures to be adopted.
- This product can be used under diverse operating conditions. Determination of applicability of equipment or devices concerned shall be determined after analysis or testing as necessary by the designer of such equipment or devices, or personnel related to the specifications. Such designer or personnel shall assure the performance and safety of the equipment or devices.
- This product is not designed or manufactured to be used for control of equipment directly concerned with human life (*1) or equipment relating to maintenance of public services/functions involving factors of safety (*2). Therefore, the product shall not be used for such applications.
 - (*1): Equipment directly concerned with human life refers to.
 - Medical equipment such as life-support systems, equipment for prerating theaters.
 - Exhaust control equipment for exhaust gases such as toxic fumes or smoke.
 - Equipment mandatory to be installed by various laws and regulations such as the Fire Act or Building Standard Law
 - Equipment related to the above.
 - (*2) : Equipment relating to maintenance of public services/functions involving factors of safety refers to.
 - Traffic control systems for air transportations, railways, roads, or marine transportation
 - Equipment for nuclear power generation
 - Equipment related to the above

CAUTIONS ON USE

- Carefully handle the units.
Do not drop, or give a strong shock or vibration to the camera. This may cause problems. Treat the camera cables carefully to prevent cable problems, such as cable breakdown and loosened connections.
- Operating ambient temperature and humidity.
Do not use the camera in places where temperature and humidity exceed the specifications. Picture quality will lower and internal parts may be damaged.
Be particularly careful when using in places exposed to direct sunlight. When shooting in hot places, depending on the conditions of the object and the camera (for example when the gain is increased), noise in the form of vertical strips or white dots may occur. This is not a malfunction.
- Restriction for the lens combination
This camera might form a ghost to image area depending on the combination of a lens and an illumination with this camera. But this is not a failure of this camera. Therefore, please check the combination of the lens and the illumination with this camera when use.
When mounting a lens, take extra caution so that the lens is not tilted, nor does flaw exist at the lens-mount-screw part. Also check to confirm that no dirt nor other foreign object is put inside
Improper mounting might cause the parts to become locked.
- Do not shoot under intense light.
Avoid intense light such as spot light on part of the screen because it may cause blooming or smears. If intense light falls on the screen, vertical stripes may appear on the screen, but this is not a malfunction.
- Do not expose the camera's image-pickup-plane to sunlight or other intense light directly.
Its inner CCD (charge-coupled device) might be damaged.
- Moire
When thin stripe patterns are shot, stripe patterns that are not actually there (moire) may appears as interference stripes. This is not a malfunction.
- Undesirable noise
If the camera or the cables are located near something which emit strong magnetism or near something which emit strong electric wave, undesirable noise may appear on the screen. In such a case, try to change the location of the camera or the cable wiring.
- Handling of the protection cap
When the camera is not in use, put a lens-cap onto the camera head for protection of the image-pickup-plane.
- When not using the camera for a longtime.
Stop supplying power for safety.
- When cleaning the camera
Always turn off the power and clean with a piece of soft dry cloth.
To remove stubborn stains, use a soft cloth soaked in diluted acid-free detergent. Do not use alcohol, benzine, thinner, etc. If used, coating and printed letters may be discolored.
In case the image-pickup-plane should be settled with fine dust, dirt, or scratched, ask your dealer for technical advice.
- Wastes of this product should be separated and discarded in compliance with the various national and local ordinances.

1. PRODUCT DESCRIPTION

Model CS8560D is an integrated type B/W CCD camera with a VGA format all-pixel-data readout CCD. This model has twice greater driving frequency of conventional cameras to achieve fast-speed data-processing. The model is suited for high-speed, high-resolution image processing use. Its compact, light-weight body is ideal for system integration.

2. FEATURES

(1) Double-speed scan

This model reads out image-data twice as fast as conventional cameras do.

(2) All pixel's data readout

With its built-in all-pixel-data-readout CCD, this model can read out image-data just in approximately 1/60 sec. A frame-shutter reads out all data even under RTS (Random Trigger Shutter) mode.

(3) High vertical resolution

As all pixel's data are read out even under RTS mode (in 1/60 sec.), images with no deterioration in vertical resolution are obtained.

(4) Square grid pattern CCD

Pixel's in CCD are aligned in square grid pattern. This makes it easier to perform computation correctly for image processing use.

(5) External Sync.

The camera is switched over to external synchronization operation automatically when external HD signal is input.

(6) Random trigger shutter function

With a built-in RTS, the camera's CCD starts light-exposure in synchronization with external trigger signals. This function enables the camera to capture fast-moving subjects at constant position for precise image processing.

(7) Restart / Reset

Under the restart / reset mode, this model can capture images at an arbitrary timing cued by external VD signal.

(8) Multiple shutter

With this shutter, this model capture images at an arbitrary timing cued by external trigger signal, and then outputs video at an arbitrary timing cued by external VD signal.

(9) Partial-scan

Under the partial scan mode, only 1/2 or 1/4 screen center portion of image information is read out, resulting in a faster operation.

(10) Ultra-compact & light-weight camera head

The model features its ultra-compact and light-weight camera head, freeing you from your integration-space-problem. In addition, it has an excellent shock and vibration resistance.

3. CONFIGURATION

- (1) Camera body..... 1
- (2) Accessory
 - Operation Manual(Japanese) 1
 - Operation Manual(English) 1

4. OPTION UNIT

- (1) DC SYNC IN cable Model name : CPRC3700 [2m,3m,5m,10m]
- (2) Camera adapter Model name : CA170
- (3) Camera-mounting kit Model name : CPT8560
- (4) Camera-connector fixing hardware
 - *Contact your dealer / distributor for details of option units.
 - *Conformity of an option part and EMC conditions
 - About the conformity of EMC standard of this machine, it has guaranteed in the conditions combined with the above-mentioned option part.
 - When used combined parts other than specification of our company, I ask you to have final EMC conformity checked of a visitor with a machine and the whole equipment.

5. OPERATION MODE

- (1) GAIN selection (Camera rear-panel SW)
 - Switches sensitivity setting
 - (1-1) FIX----- Factory-prefixed gain
 - (1-2) MANU----- Gain is adjustable via the manual gain potentiometer (M.GAIN)
- (2) Video output mode selection (Camera rear-panel DIP SW)
 - Switches video format
 - (2-1) 1/60: 1/60s ----- Non-interlace mode
 - As all pixels are read out in 1/60s, you will get images with the higher V resolution.
 - (2-2) 1/120: 1/120s ----- 2:1 interlace MIX mode
 - As vertical pixels are added in readout, the sensitivity is same as that of 1/60s non-interlace mode during electronic shutter OFF.
 - Twice greater sensitivity is obtained under shutter-speed range of 1/200 – 1/20000.
- (3) RTS (Random Trigger Shutter) exposure selection (Camera rear-panel DIP SW)
 - Switches light exposure mode under RTS mode
 - (3-1) FIX mode ----- Rear DIP SW
 - Exposure-time control via rear-panel DIP switch
 - (3-2) PULSE W mode---- TRIG signal pulse width control
 - Exposure-time control via TRIG signal pulse width

(4) Shutter mode selection (Camera rear-panel DIP SW or TRIG signal IN [Automatic])

Switches shutter mode

(4-1) NOR mode ----- Normal electronic shutter

Exposure control via internal sync signal

High-speed shutter: From 1/20,000s through OFF (8 position)

(4-2) RTS mode ----- Random trigger shutter

Exposure control via ext. trigger or ext. sync input

Timing charts are shown below. (TRIG timing: Positive)

Notes: * RTS selection is automatic with TRIG status

** Neither under FIX nor PULSE W mode, RTS doesn't work if Electronic shutter speed SW is set in OFF position.

(a) Non-reset mode (Under internal sync / external sync --- Consecutive VD IN)

Exposure starts at the timing of TRIG signal IN. After each exposure is completed, the camera outputs video at each next VD IN timing.

1/60s Non-interlace

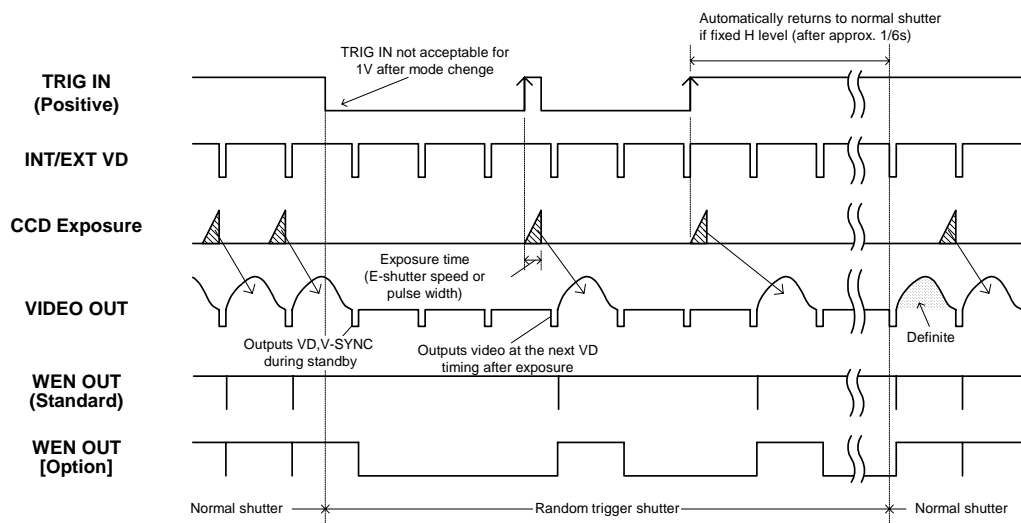

1/120s 2:1 Interlace

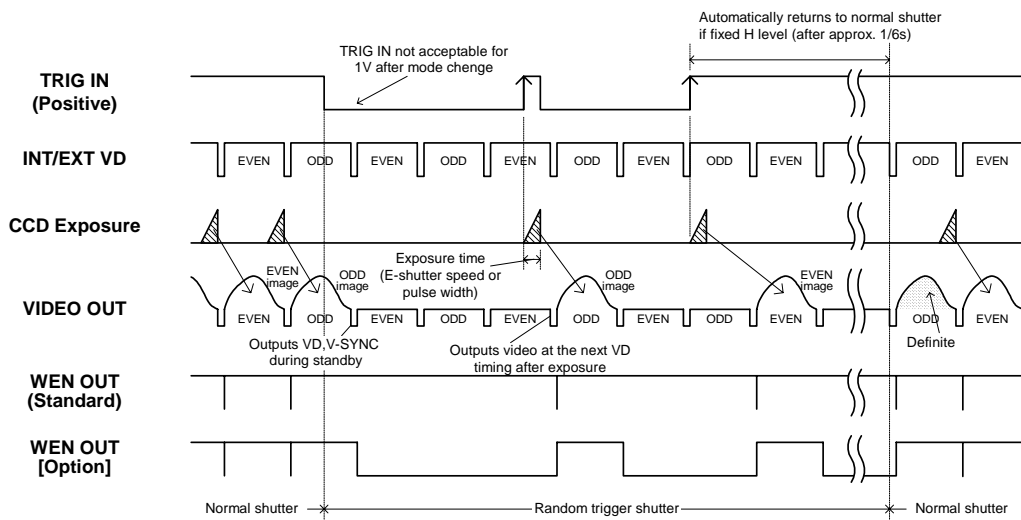

(b) Non-reset mode (Under external sync --- Single VD IN)

After TRIG IN and exposure, the camera goes into standby until next ext. VD IN.

1/60s Non-interlace

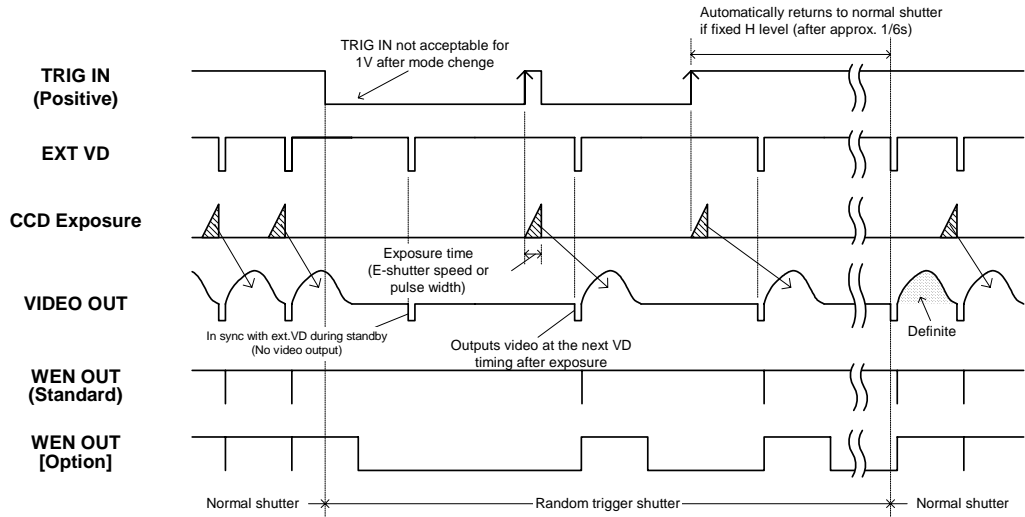

*Don't provide ext. VD IN during exposure.

** After automatic return, fix ext. VD IN at Hi.

1/120s 2:1 Interlace

Video output field (ODD/EVEN) is determined by ext. VD falling edge and ext. HD phase.

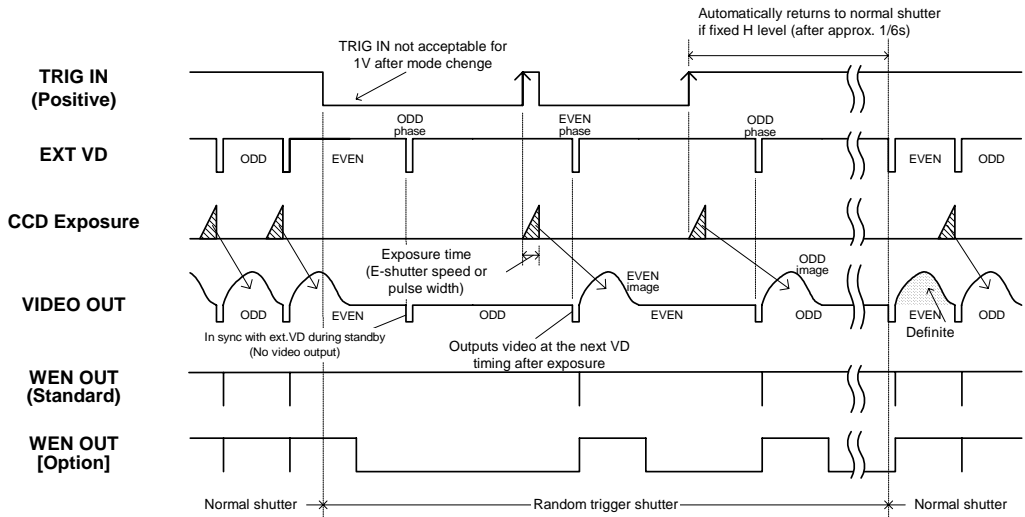

*Don't provide ext. VD IN during exposure.

** After automatic return, fix ext. VD IN at Hi.

(c) V-reset mode (Under internal sync / external sync --- No VD IN)

Exposure starts at the timing of TRIG signal IN. After each exposure is completed, the camera outputs video immediately by resetting VD. (HD is not reset)

1/60s Non-interlace

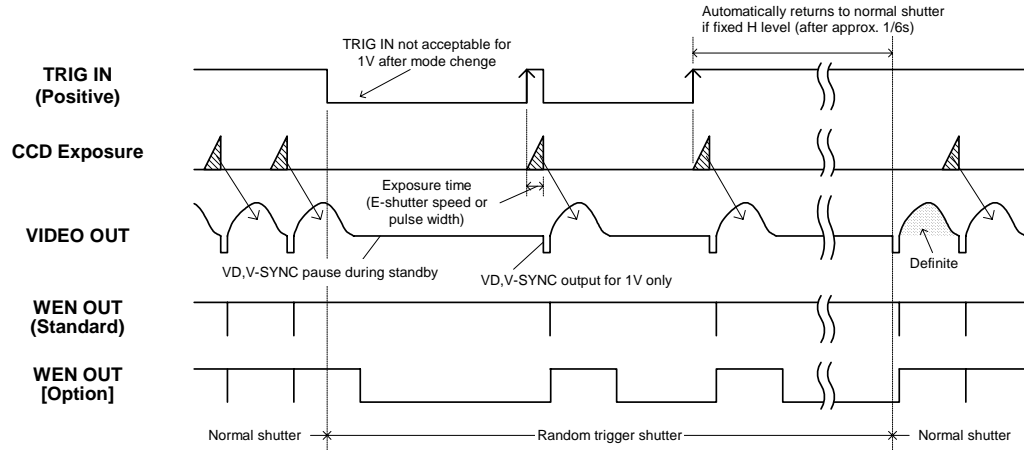

1/120s 2:1 Interlace

Irrespective of TRIG IN phase, the camera always outputs ODD field image.

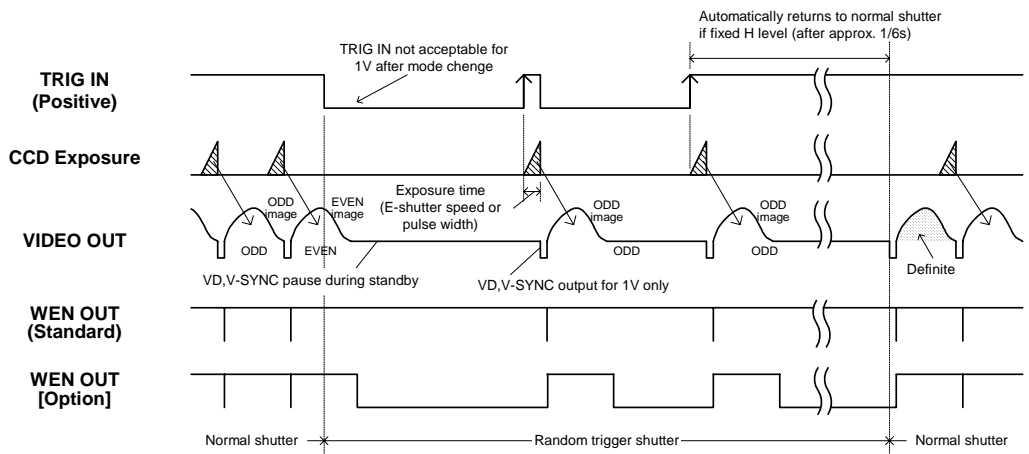

(d) SYNC reset mode (Under internal sync)

Exposure starts at TRIG signal input timing, resets HD, and outputs video immediately after exposure by resetting VD.

* Available under FIX mode only.

1/60s Non-interlace

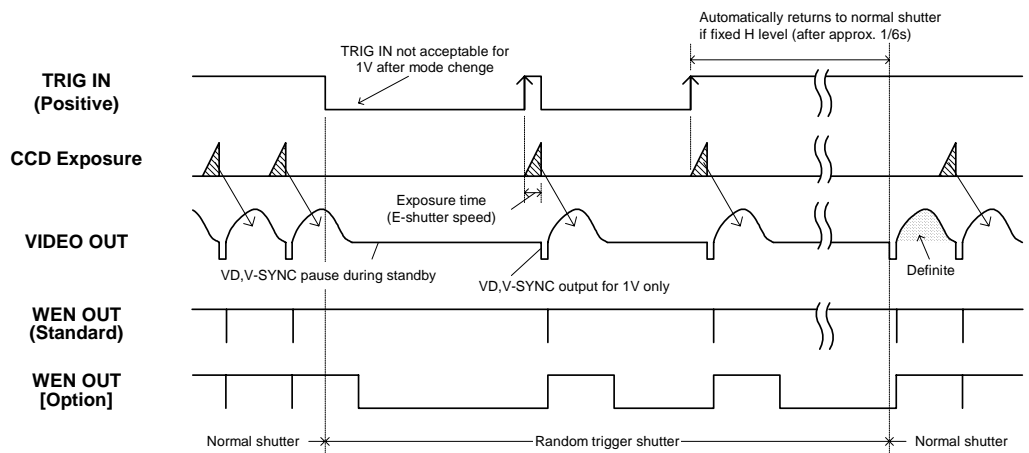

1/120s 2:1 Interlace

Irrespective of TRIG IN phase, the camera always outputs ODD field image.

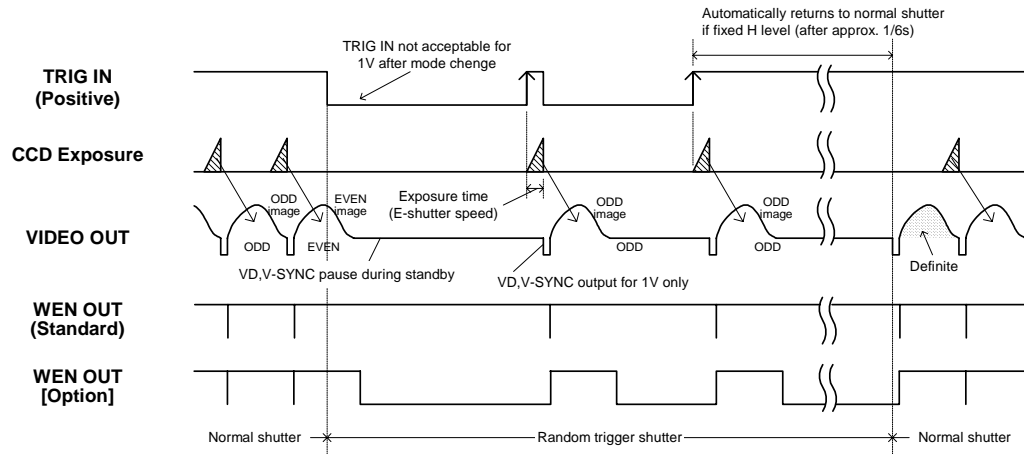

(4-3) MULTIPLE SHUTTER mode

Multiple shutter operation is available by providing TRIG IN more than one time before ext. VD IN. (Non-reset mode, single VD, consecutive VD IN)

1/60s Non-interlace

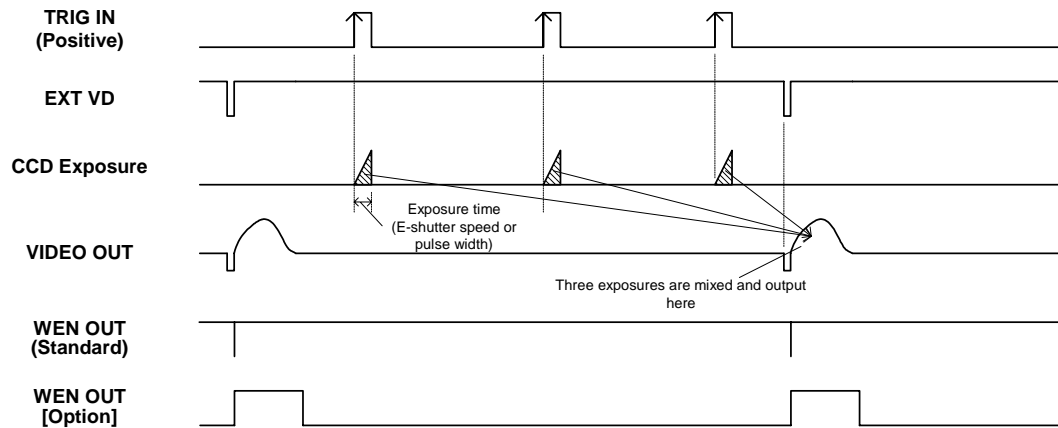

1/120s 2:1 Interlace

Video output field (ODD/EVEN) is determined by ext. VD falling edge and ext. HD phase.

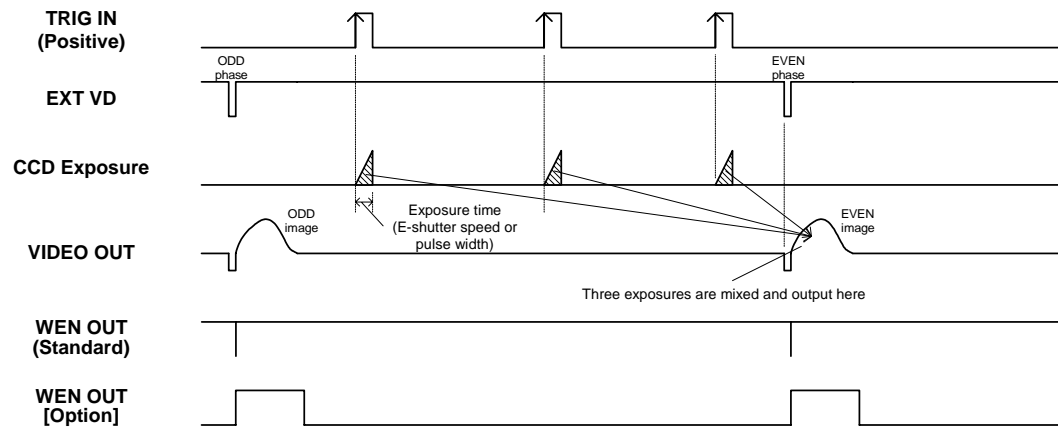

■ RTS TRIG IN notes

1/60s Non-interlace

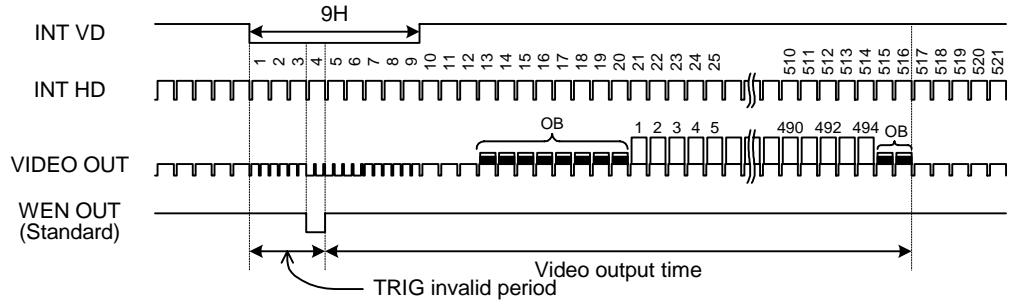

1/120s Interlace ODD Field

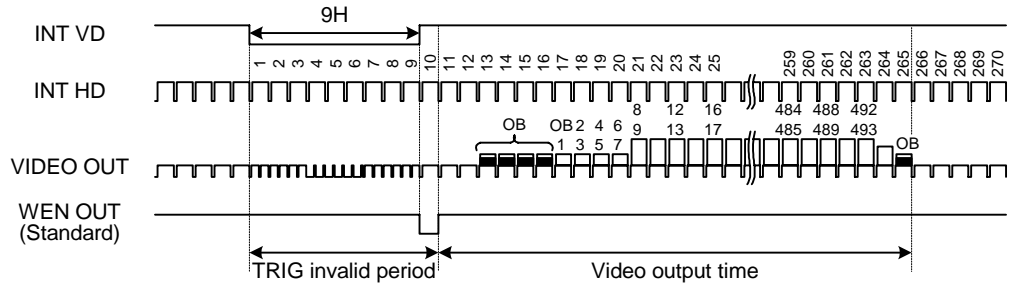

1/120s Interlace EVEN Field

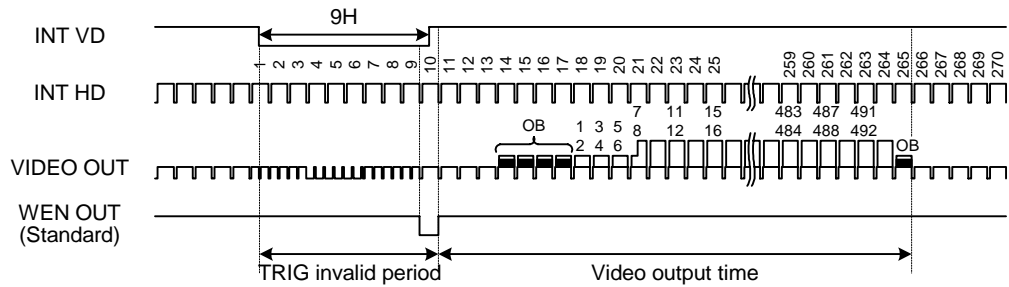

- * TRIG becomes invalid even if TRIG (exposure start) is inputted during TRIG invalid period.
- * An image may be affected if TRIG (exposure start) is inputted during the video output time.
- * An image may not be outputted normally if exposure is terminated during the video output time.

■ Exposure time delay under RTS

When the RTS is active, both in FIX mode and PULSE W mode, there is a time delay of approximately 1.4 micro s until the start of exposure after the rising edge of TRIG signal (positive).

■ Exposure time under pulse width mode

Under RTS pulse mode, the exposure time is determined by the pulse width. More exactly, the actual time is the pulse width plus approximately 8.0 micro s.

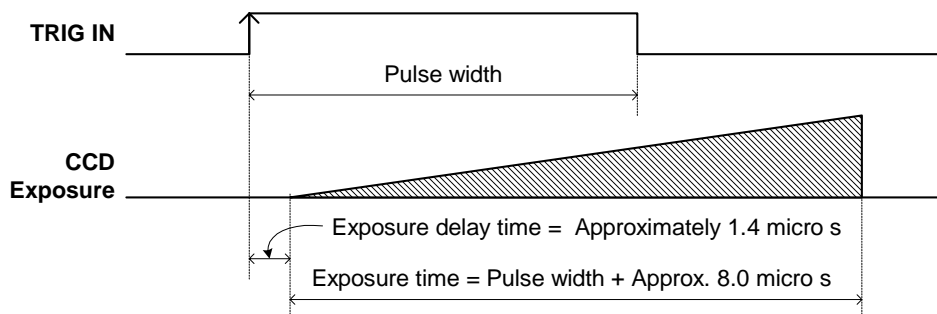

(5-4) Restart / Reset

The restart / reset function is available with the ext.VD signal. You can get an arbitrary slower shutter speed than normal shutter and random trigger shutter.

Here are some notes;

- * The shutter speed (exposure time) is determined by ext. VD signal interval.
- ** This function is enabled when the rear-panel shutter speed DIP SW is OFF.
- *** Supply consecutive HD.

1/60s Non-interlace

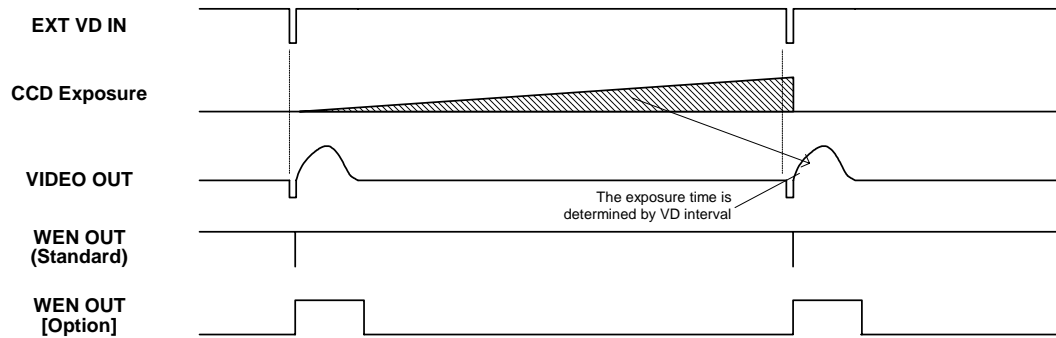

1/120s 2:1 Interlace

Video output field (ODD/EVEN) is determined by ext. VD falling edge and ext. HD phase.

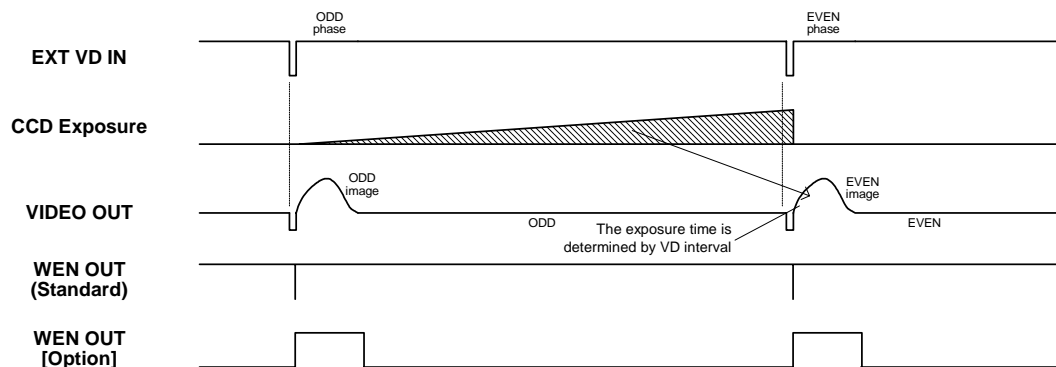

(5) Partial-scan mode selection (Camera rear-panel DIP SW)
Switches partial-scan mode

Note: Sometimes phenomenon called as “whiteout” occurs at the top of the screen when there is strong incident light entering in the wide area of a CCD, however, this is not a malfunction. If this occurs, reduce the amount of incoming rays.

(5-1) 1/2 Partial-scan (Rear-panel SW: #8-OFF, #9-ON) --- Screen center 1/2 readout

1/60s Non-interlace

Under 1/60s non-interlace mode, only the center portion of 227H out of the total effective lines 494H (excluding BLK time) is read out. Available both under external / internal mode.

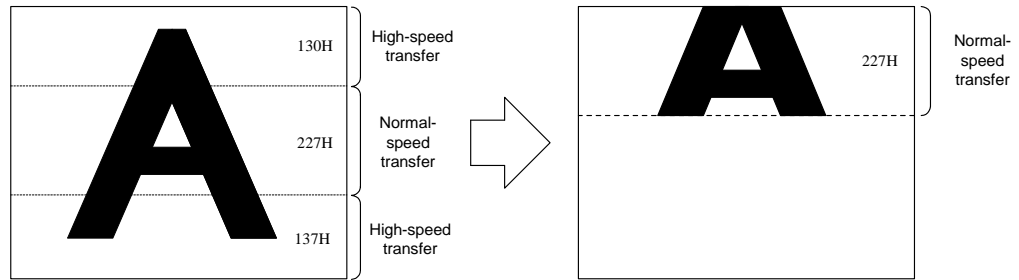

Under normal shutter (Electronic shutter OFF)

Notes: * Under ext. sync, the ext. VD should be 1V = 262H.

** Under normal shutter, set the rear-panel DIP SW #6, #7 in OFF.

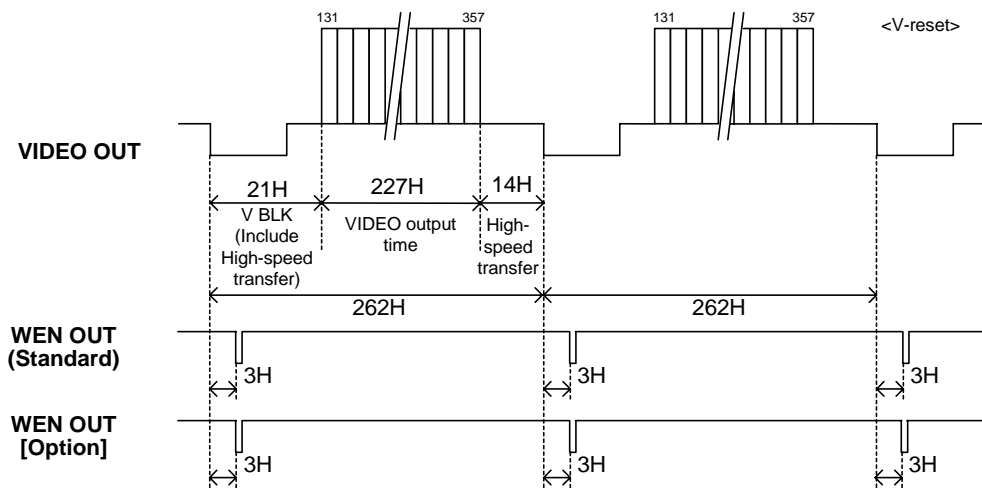

Under other shutter modes

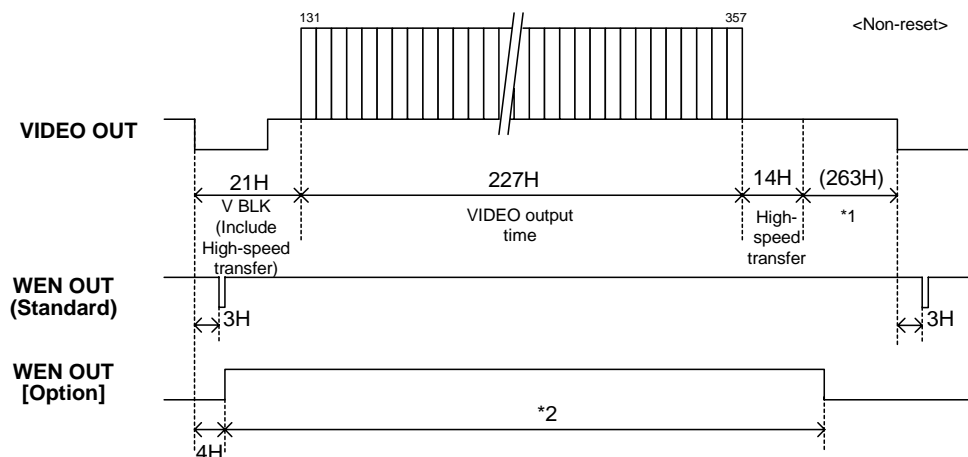

*1: Arbitrary under ext.sync

*2: See "7.TIMING CHART (4)WEN timing".

1/120s 2:1 Interlace

Under 1/120s interlace mode, only the center portion of 207H out of the total effective lines 485H (excluding BLK time) is read out. Available both under external / internal mode.

ODD Field

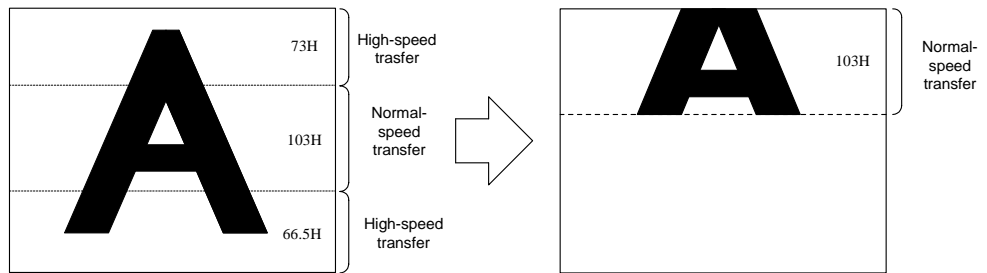

EVEN Field

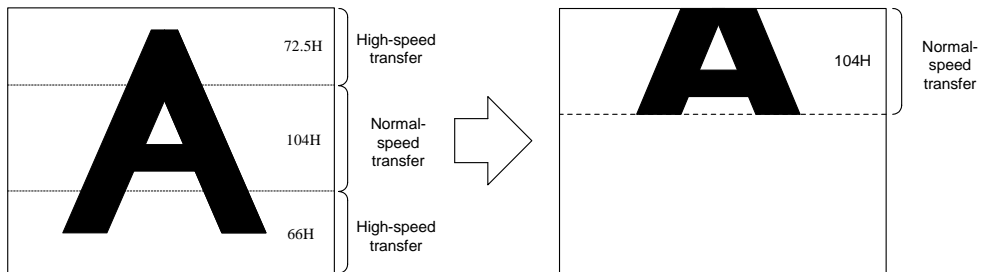

Under normal shutter (Electronic shutter OFF)

Notes: * Under ext. sync, the ext. VD should be $1V = 131.5H$.

** Under normal shutter, set the rear-panel DIP SW #6, #7 in OFF.

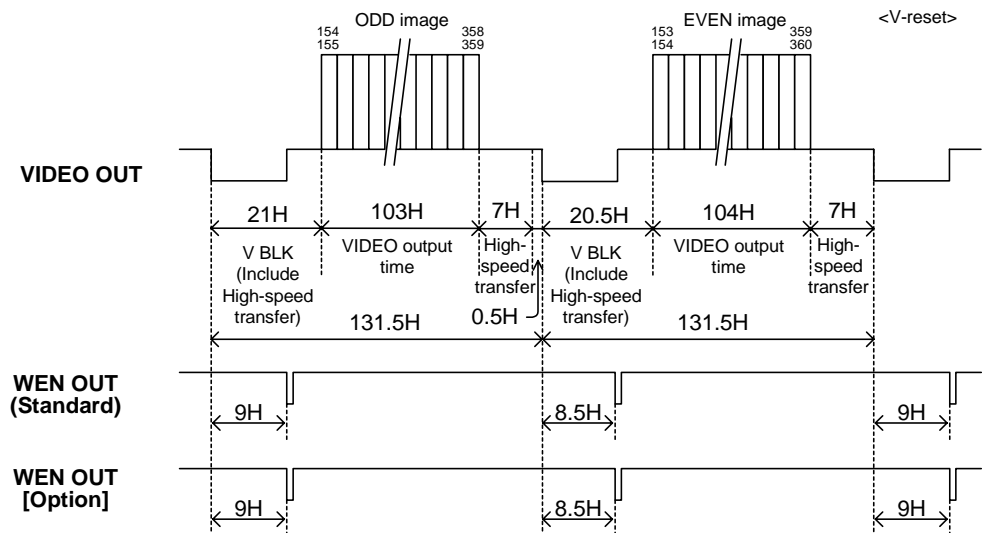

Under other shutter modes

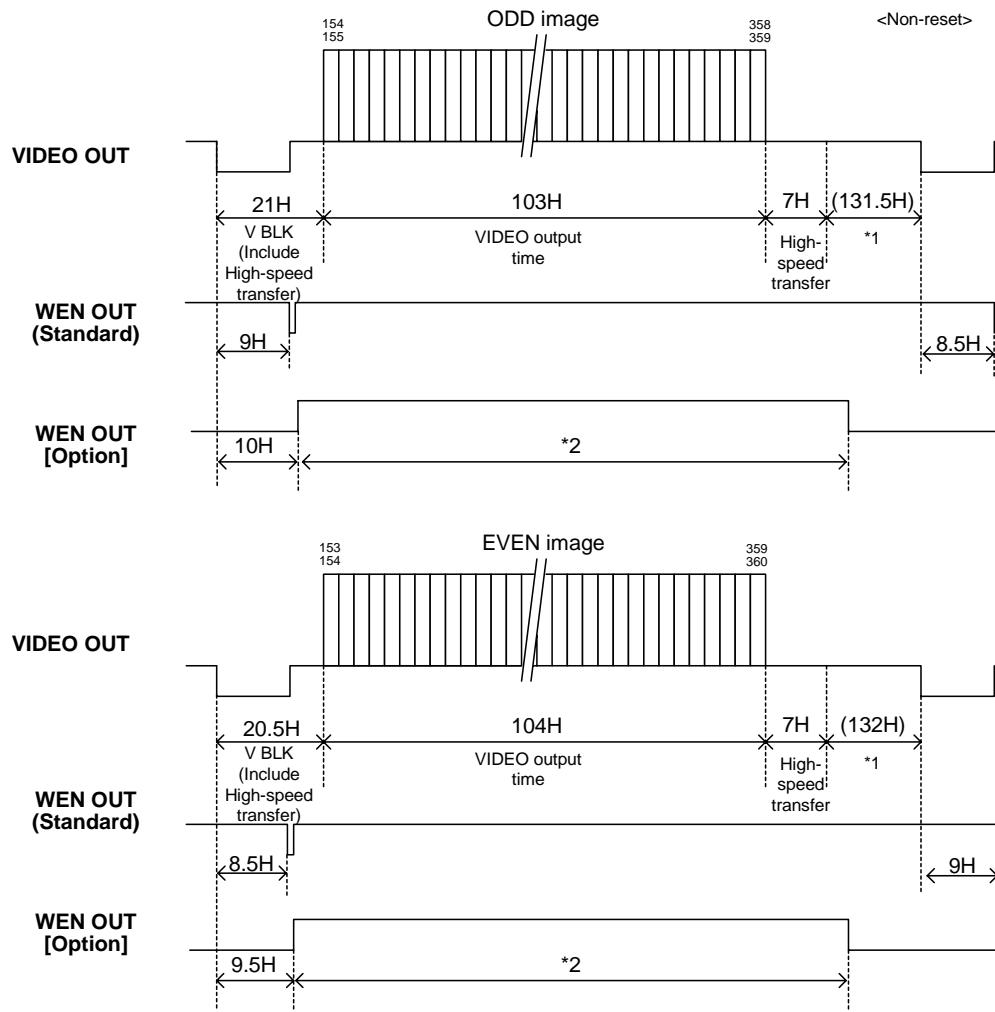

*1: Arbitrary under ext.sync
 *2: See "7.TIMING CHART (4)WEN timing".

(5-2)1/4 Partial-scan (Rear-panel SW: #8-ON, #9-ON) --- Screen center 1/4 readout

1/60s Non-interlace

Under 1/60s non-interlace mode, only the center portion of 81H out of the total effective lines 494H (excluding BLK time) is read out. Available both under external / internal mode.

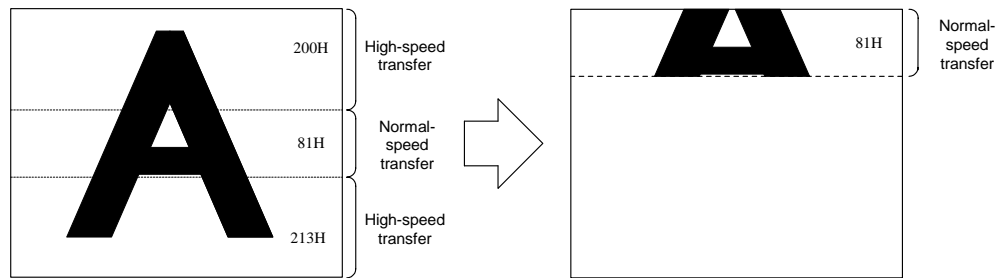

Under normal shutter (Electronic shutter OFF)

Notes: * Under ext. sync, the ext. VD should be 1V = 131H.

** Under normal shutter, set the rear-panel DIP SW #6, #7 in OFF.

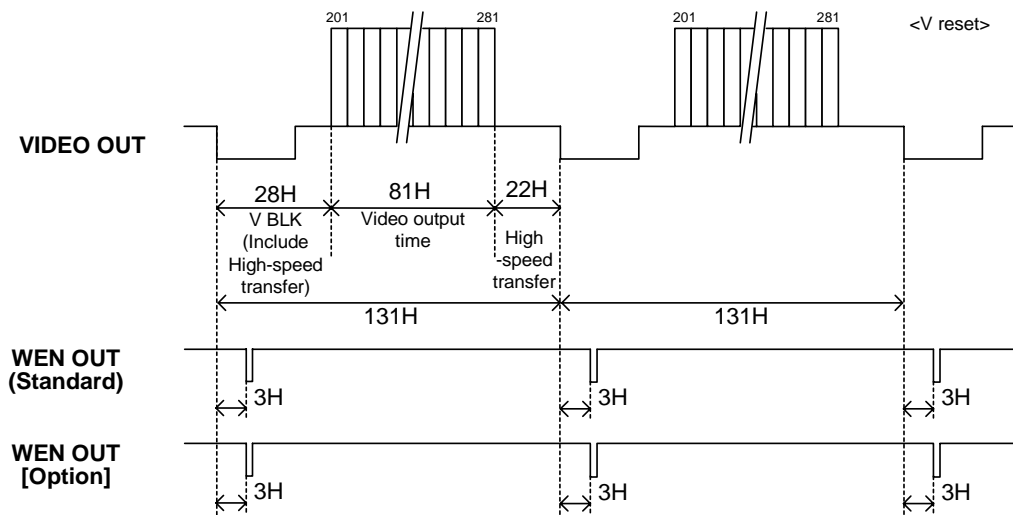

Under other shutter modes

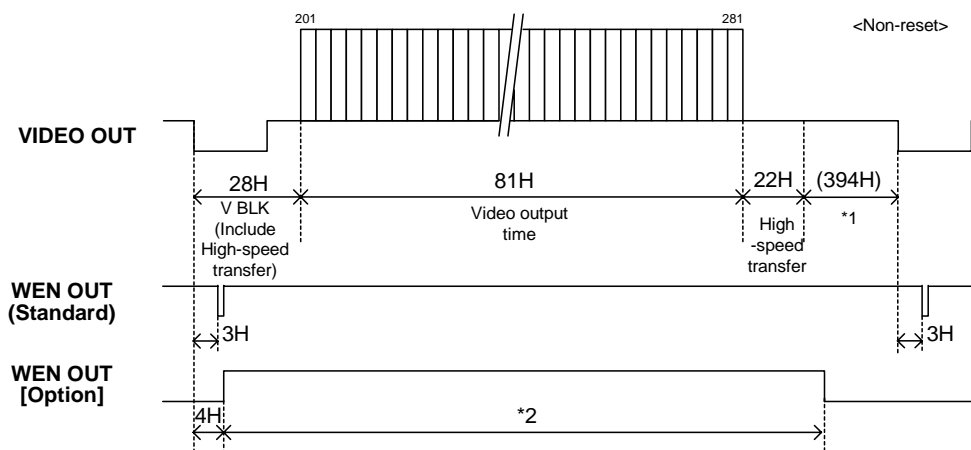

*1:Arbitrary under ext.sync

*2:See "7.TIMING CHART (4)WEN timing".

1/120s 2:1 Interlace

Under 1/120s interlace mode, only the center portion of 61H out of the total effective lines 485H (excluding BLK time) is read out. Available both under external / internal mode.

ODD Field

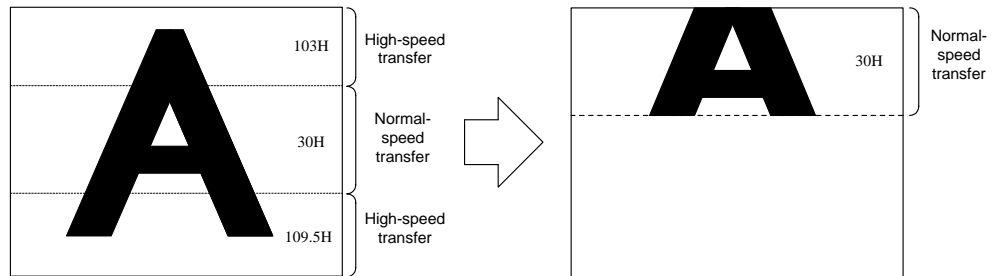

EVEN Field

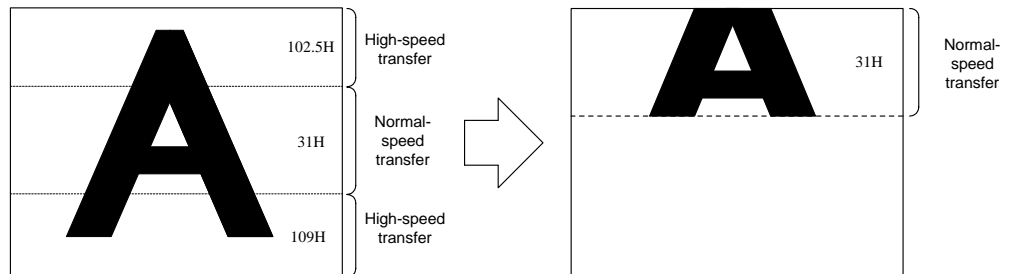

Under normal shutter (Electronic shutter OFF)

Notes: * Under ext. sync, the ext. VD should be $1V = 65.5H$.

** Under normal shutter, set the rear-panel DIP SW #6, #7 in OFF.

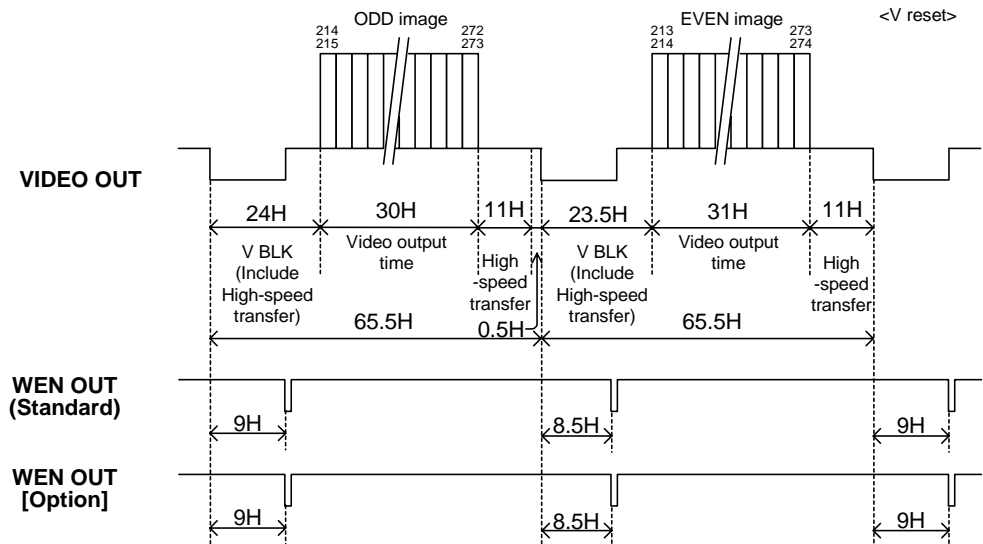

Under other shutter modes

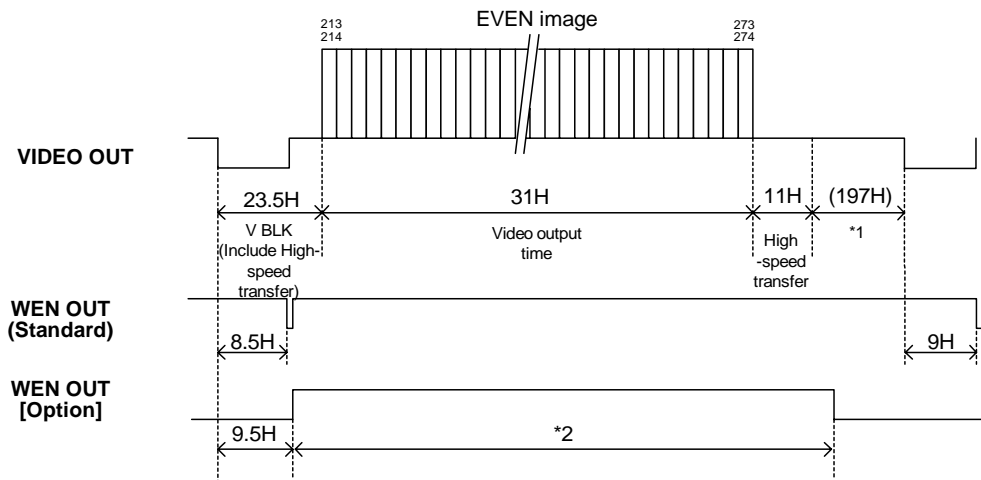
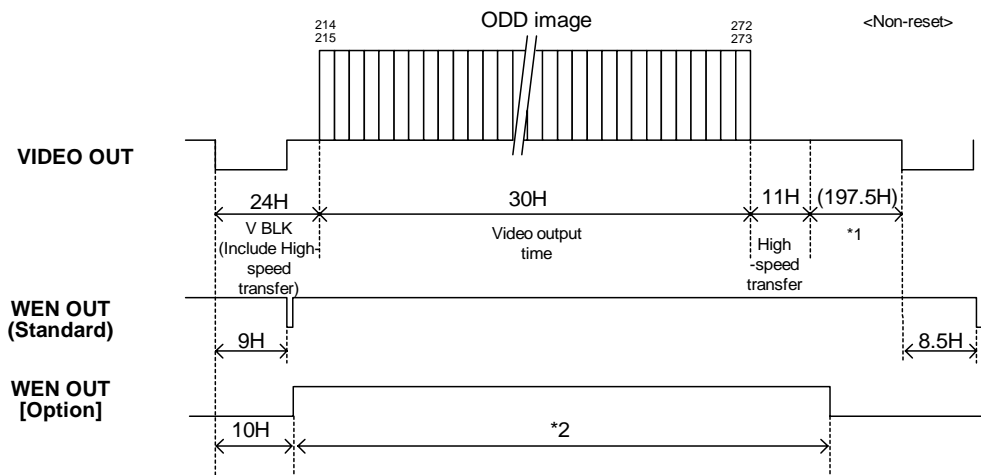

*1:Arbitrary under ext.sync
 *2:See "7.TIMING CHART (4)WEN timing".

(5-3) Programmable partial **[Option]**

By designating the high-speed transfer portion with external PARTIAL signal input, the camera read out only the portion of CCD area necessary for your application. This is available under ext. sync.

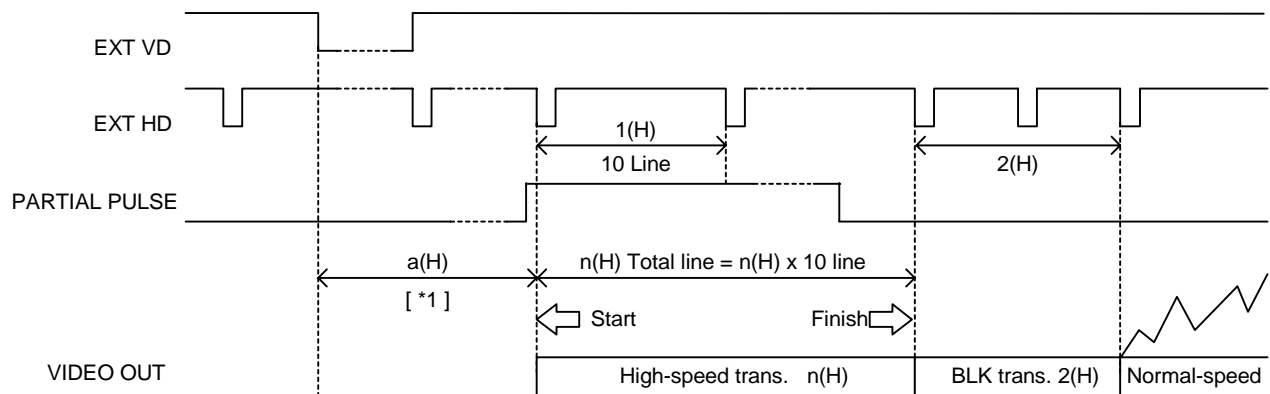

[*1]	1/60s non-interlace	1/120s Interlace	
		1st field	2nd field
a(H)	6.0	12.0	11.5

(Conditions)

- The starting point of external partial signal is [*1] from the falling edge of ext. VD.
- The external partial signal is controlled at each ext. HD falling edge. Set the start / finish of the external partial signal in 1H increments.
- The number of 1H high-speed transfer line is 10 lines. The actual lines are determined by the external partial signal “hi” period. (Minimum: 2H = 20 lines)
- Set video output time more than 30H. And high-speed transfer time (the external partial signal “hi” period) before video output time is as follows;
 - from 2H through 22H under 1/60s non-interlace mode
 - from 2H through 11H under 1/120s interlace mode
- After high-speed transfer, 2H is allocated to blank transfer period. Normal transfer starts at the next line.
- VIDEO OUT vertical blanking is;
 - V. blanking = [*1](H) + n(H) + BLK transfer [2(H)] – 1H

Example follows below.

(High-speed 2H = 20 lines (minimum), Normal-speed 70 lines + BLK 2H)

Note: Items shown as [Option] in this document is not included in your purchase as standard components. Contact our dealer / distributor for details.

1/60s Non-interlace

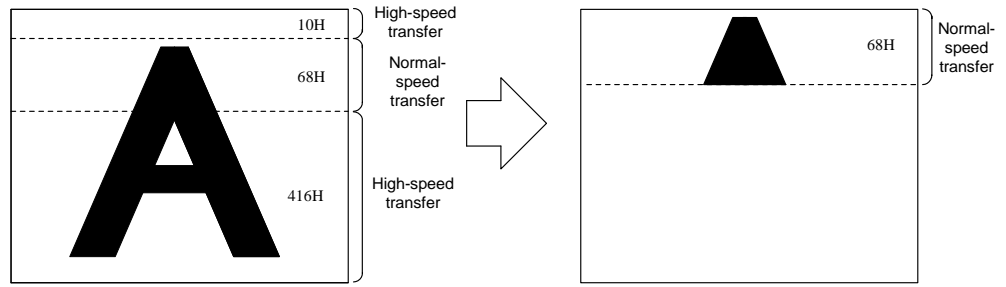

The timing is as follows;

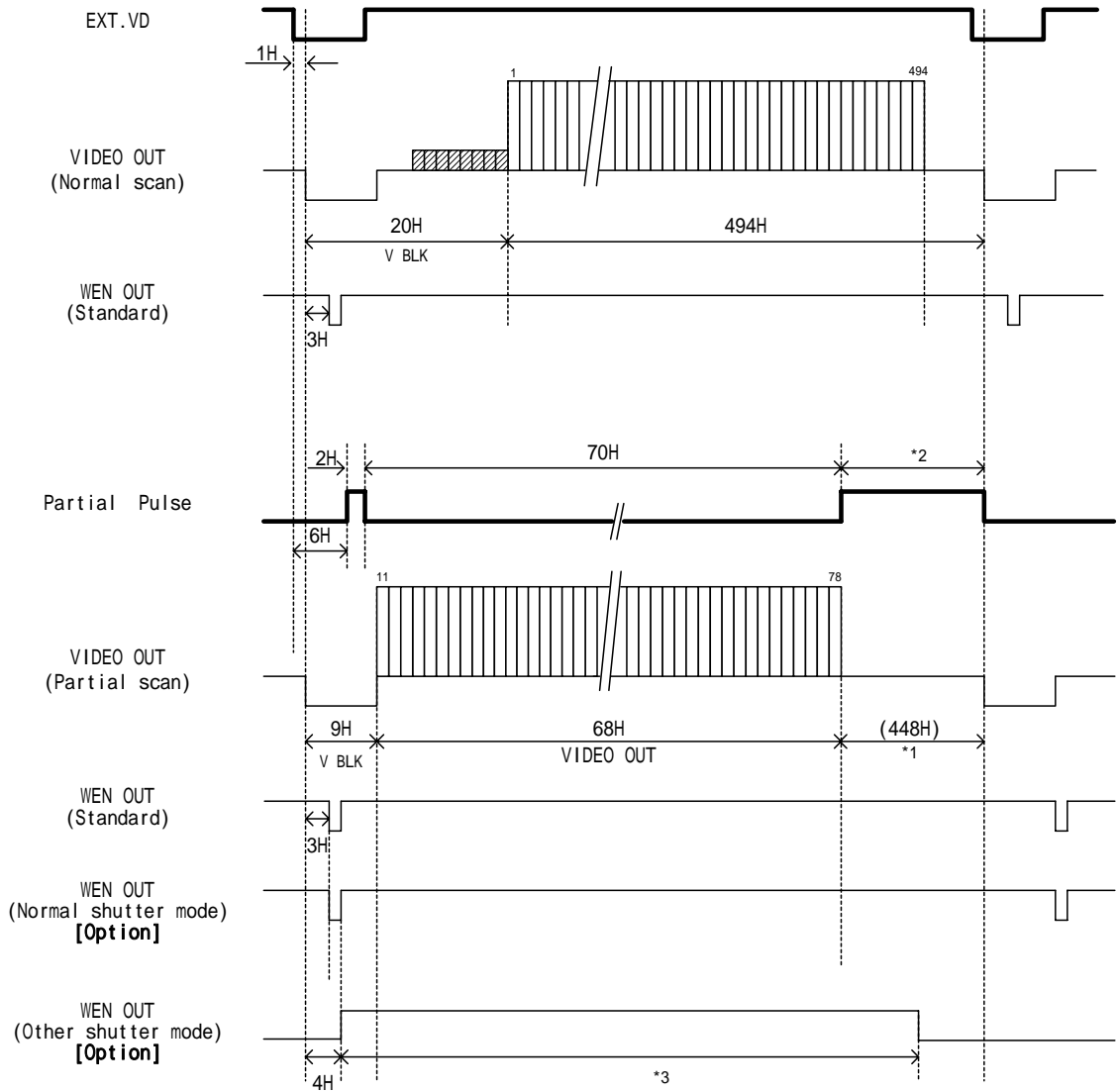

*1:Arbitrary under ext.sync.
 *2:Partial over actual line is OK.
 *3:See "7.TIMING CHART (4)WEN Timing".

1/120s 2:1 Interlace, ODD field

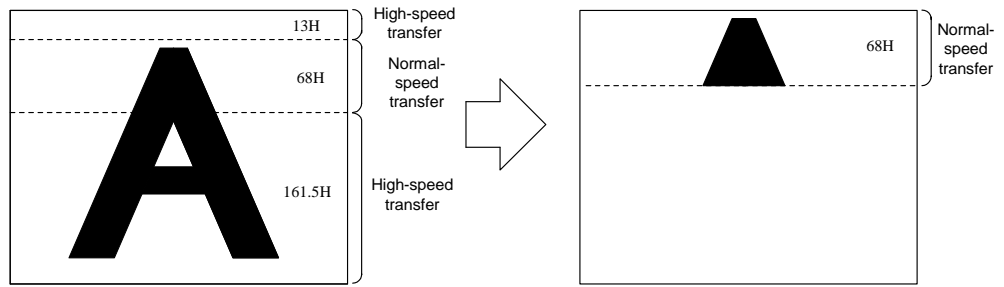

The timing is as follows;

ODD Field

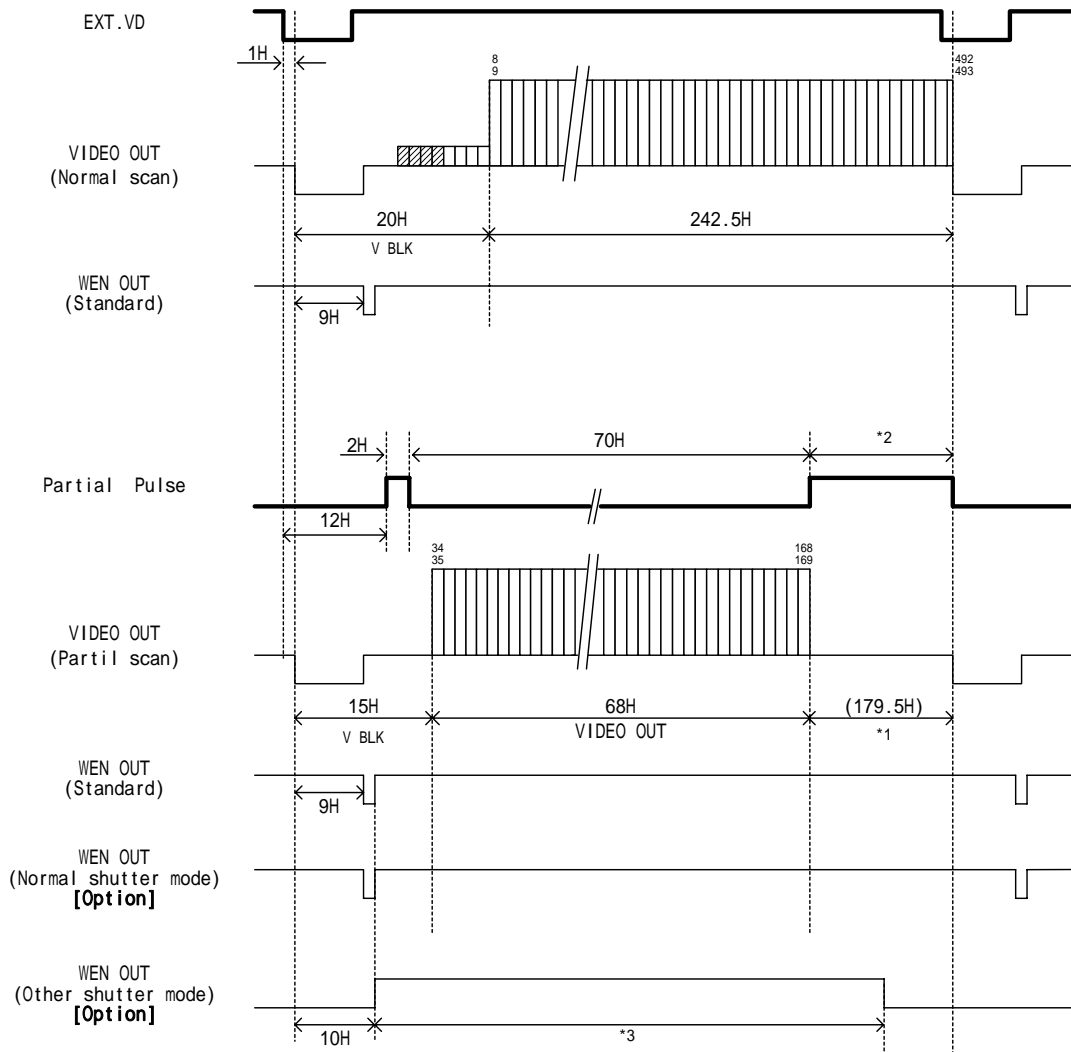

*1:Arbitrary under ext.sync.
 *2:Partial over actual line is OK.
 *3:See "7.TIMING CHART (4)WEN Timing" .

1/120s 2:1 Interlace, EVEN field

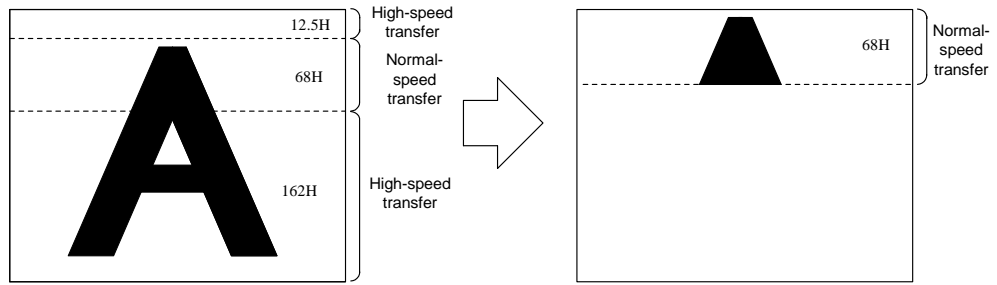

The timing is as follows;

EVEN Field

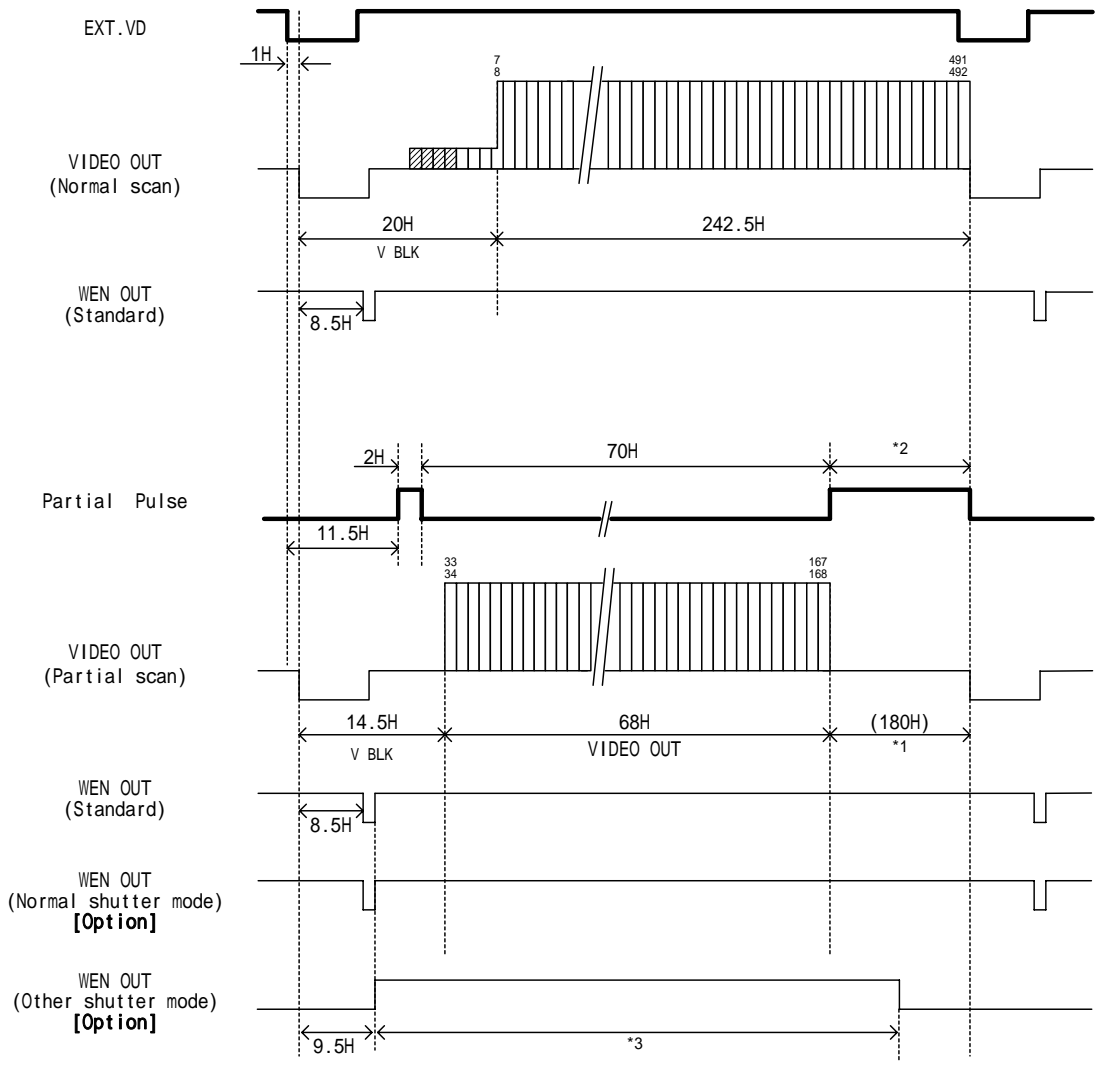

*1:Arbitrary under ext.sync.
 *2:Partial over actual line is OK.
 *3:See "7.TIMING CHART (4)WEN Timing".

Note: Items shown as [Option] in this document is not included in your purchase as standard components. Contact our dealer / distributor for details.

6. SPECIFICATIONS

[Basic spec]

(1) Image sensor	All Pixel's Data Read-out Interline CCD
Total pixels	692(H) x 504(V)
Active pixel	659(H) x 494(V)
Video output pixels	648(H) x 494(V) (Under non-interlace)
Scanning area	4.88(H) x 3.66(V) mm (=Equivalent to 1/3 type CCD size)
Unit cell size	7.4(H) x 7.4(V) micro m (Square-grid array)
(2) TV system	Special format (Non-conforming to EIA)
(3) Scanning lines	525 lines
(4) Interlace	1/60s Non-interlace mode 1/120s 2:1 Interlace mode Switching via rear-panel DIP SW
(5) Sync system	Internal/External automatic switch-over
(6) Aspect ratio	4:3
(7) Video output	VS 1.0V(p-p) / 75 , DC coupled, 1 line (AC as [Option])
(8) Resolution	485 TV lines(H) 485 lines (350 TV lines)(V)
(9) S/N	Standard: 52dB(p-p)/rms (Initial factory setting)
(10) Illumination	Standard 400 lx (F5.6) Minimum 4 lx (F1.4) (GAIN MAX, Approx. 50% video output)
(11) Gain	FIX (Fixed) gain: Factory-shipped preset level MANU (Manual) gain: Setting through GAIN VR FIX / MANU switching via rear-panel DIP SW
(12) Gamma correction	Gamma = 1 (Fixed)
(13) White-clip level	Approx. 840mV(p-p) (Excluding SYNC)
(14) Power source	DC12V \pm 10% Ripple voltage: 50mV(p-p) or less
(15) Power consumption	Approx. 1.5W

[Internal sync spec]

(1) Base clock frequency	24.545MHz (1CLK) \pm 200ppm
(2) H sync frequency	31.468kHz (1H = 780CLK)
(3) V sync frequency	59.94Hz (Under non-interlace) 119.88Hz (Under 2:1 interlace)

Note: Items shown as [Option] in this document is not included in your purchase as standard components. Contact our dealer / distributor for details.

[External sync spec]

- (1) Ext. sync input signal HD/VD
- (2) Input impedance 75-ohm / High impedance 10k-ohm (switching via rear-panel SW)
(Initial factory setting: High)
- (3) Input level From 2 through 5V (p-p) under high impedance input
From 2 through 4V (p-p) under 75-ohm input
- (4) Interlace 1/60s non-interlace or 1/120s 2:1 interlace
- (5) Polarity Negative
- (6) Pulse width HD: 3.2 +/- 1 micro s (LOW)
VD: From 125 through 400 micro s (LOW)
- (7) Repeating frequency $f_H = 31.468\text{kHz} \pm 1\%$
 $f_V = f_H/262.5$ or $f_H/525$
- (8) Phase difference HD/VD: 0 +/- 5.0 micro s, $1/f_H/2 \pm 5.0$ micro s

[Shutter trigger spec]

- (1) Input level Exposure-starting-cue signal in random trigger shutter mode
LOW level: From 0 through 0.5V(p-p)
HIGH level: From 4 through 5V(p-p)
- (2) Input impedance High impedance (10k-ohm)
- (3) Capture timing Rising edge detection (Positive)
(Falling edge detection (Negative) as **[Option]**)
- (4) Pulse width Minimum 2 micro s
Maximum 1/8s

[Sync signal spec]

- (1) Readout signal WEN readout timing pulse
- (2) Polarity Negative (Positive under VIDEO output mode **[Option]**)
- (3) Pulse width 1H output (Available under VIDEO output mode **[Option]**)

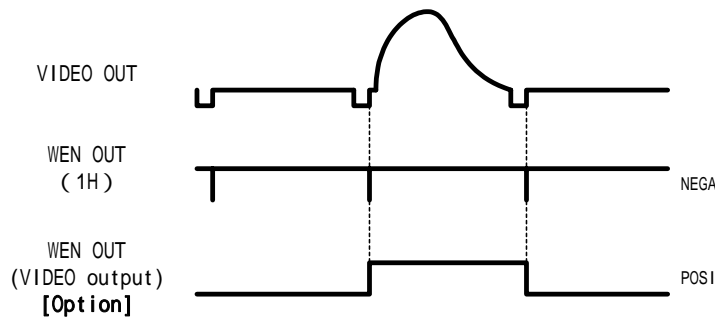

- (4) Output circuit * Set WEN termination to be high impedance.

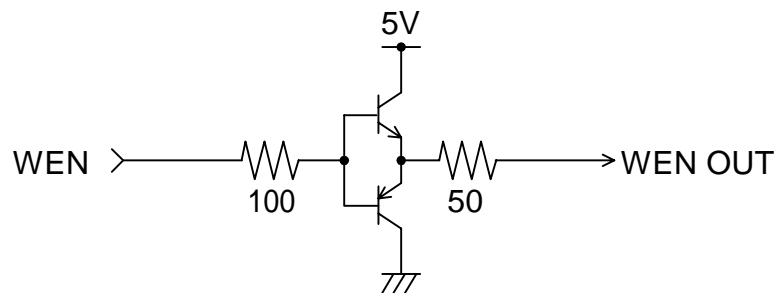

Note: Items shown as [Option] in this document is not included in your purchase as standard components. Contact our dealer / distributor for details.

[Electronic shutter spec]

(1)Normal shutter

Shutter-speed setting via rear-panel SW (Initial: OFF)

8 steps switch-able (= OFF, 1/200s, 1/500s, 1/1000s, 1/2000s, 1/4000s, 1/8000s, 1/20000s)

(2)RTS

(a)Operation mode

No.	Reset	Exposure	Sync
1	Non-reset	Rear SW (FIX mode)	Internal
2			Consecutive HD / Consecutive VD IN
3			Consecutive HD / Single VD IN
4		TRIG pulse width (PULSE width mode)	Internal
5			Consecutive HD / Consecutive VD IN
6			Consecutive HD / Single VD IN
7	V-reset	Rear SW (FIX mode)	Internal
8			Consecutive HD IN
9	SYNC reset		Internal
10	V reset	TRIG pulse width (PULSE width mode)	Internal
11			Consecutive HD IN

Notes : * RTS mode automatically switches over through TRIG IN

**RTS disabled under Electronic shutter OFF

(b)Multiple shutter

Multiple shutter via ext. trigger signal and ext. VD signal

Notes : * Operation like No.3, 6 above

(3)Restart / Reset

Restart / reset available via ext. VD signal

(Switching via rear panel DIP SW, Initial OFF)

Notes : * The exposure-time (shutter-speed) is determined by ext. VD interval.

** Enabled when rear-panel DIP SW OFF.

***Provide Consecutive HD.

[Partial scan]

(1)Operation mode

No	Scan mode	Sync	Reset	E-shutter Normal	E-shutter RTS
1	1/2 partial	Internal	Non-reset	Enabled [Option]	Enabled
2			V-reset	Disabled	
3		Consecutive HD VD IN	Non-reset	Enabled [Option]	Enabled
4		Consecutive HD (VD) IN	V-reset	Disabled	
5	1/4 partial	Internal	Non-reset	Enabled [Option]	Enabled
6			V-reset	Disabled	
7		Consecutive HD VD IN	Non-reset	Enabled [Option]	Enabled
8		Consecutive HD (VD) IN	V-reset	Disabled	
9	Programmable	Consecutive HD VD IN	Non-reset	Enabled [Option]	Enabled [Option]

Note: Items shown as [Option] in this document is not included in your purchase as standard components. Contact our dealer / distributor for details.

(2) Reset mode

As shown in (1) above, non-reset and V-reset is available.

([Option]: Doesn't come as standard. Contact our dealer / distributor for details)

(a) non-reset (Electronic shutter enabled)

VD doesn't get reset after video readout. The interval of VD signal is as follows.

	1/2 partial scan	1/4 partial scan
1/60s non-interlace	525H	525H
1/120s interlace	262.5H	262.5H

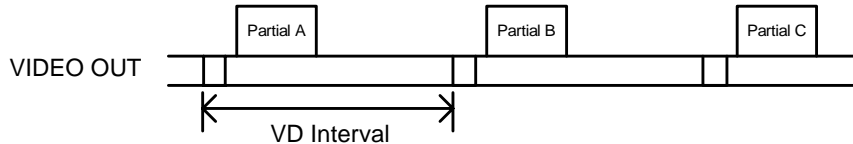

*Note: Under normal shutter mode, when non-reset is selected on partial scan, electronic shutter is valid.

Please note that the exposure time is shortened than the setting value when the external VD is input at shorter than the above VD interval.

(b) V-reset (Electronic shutter disabled)

VD does get reset after video readout. Under internal sync, the interval of VD signal is as follows.

	1/2 partial scan	1/4 partial scan
1/60s non-interlace	262H	131H
1/120s interlace	131.5H	65.5H

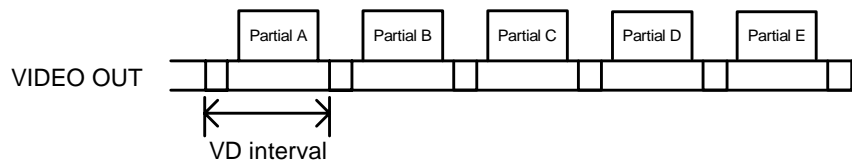

(3) Partial signal **[Option]**

Programmable mode input signal

- (a) Input level LOW level: From 0 through 0.5V
 HIGH level: From 4 through 5V
- (b) Input impedance High impedance (10kΩ)
- (c) Polarity Positive (Hi: High-speed transfer)

Note: Items shown as [Option] in this document is not included in your purchase as standard components. Contact our dealer / distributor for details.

[Mechanical spec]

- | | |
|------------------------|--|
| (1) External dimension | 29 x 29 x 39.5(D) mm (Not including protrusion)
Refer to the attached external view drawing |
| (2) Weight | Approximately 42g |
| (3) Lens mount | C mount |
| (4) GND / insulation | Circuit GND - Chassis electrically conducted |

[Ambient condition]

- (1) Environment condition
- | | |
|------------------------|---|
| Performance guaranteed | Temperature: From 0 through 40 °C
Humidity: From 30 through 90 % (No condensing) |
| Operation guaranteed | Temperature: From -5 through 45 °C
Humidity: From 10 through 90 % (No condensing) |
| Storage | Temperature: From -20 through 60 °C
Humidity: From 10 through 90 % (No condensing) |
- (2) EMC conditions (Electro-Magnetic Compatibility)
- EMI (Electro-Magnetic Interference)
EN61000-6-4 Conformity
- EMS (Electro-Magnetic Susceptibility)
EN61000-6-2 Conformity

***Conformity of EMC conditions**

About the conformity of the EMC standard of this machines, it has guaranteed in the conditions combined with the option part of 4th clause.

When used combining parts other than specification of our company, I ask you to have final EMC conformity checked of a visitor with a machine and the whole equipment.

[Connector pin assignment]

(1) Compatible connector HR10A-10P-12S (Supplied by HIROSE ELEC.)

(2) Pin assignment

Connector pin layout

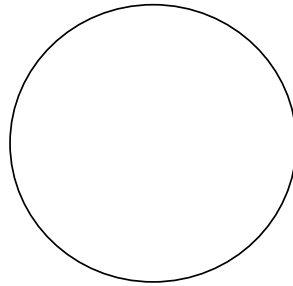

Picture Rear-panel camera connector
(Rear-view)

12 pin male

Pin No.	Signal (Standard)	Signal [Option]	
1	DC12V GND		
2	DC12V		
3	VIDEO GND		
4	VIDEO OUT		
5	HD GND		
6	HD IN		
7	VD IN		
8	TRIG GND	NC	
9	NC	TRIG IN	
10	WEN OUT	GND	
11	TRIG IN	DC12V	NC
12	VD GND	PARTIAL	

Notes : *Before connecting / disconnecting the connector, make sure the camera power is OFF.
**For board connection, check compatibility.

Note: Items shown as [Option] in this document is not included in your purchase as standard components. Contact our dealer / distributor for details.

[Switch setting]

(1) CCU rear-panel DIP SW

No.	Function	OFF	ON
1	GAIN selection (GAIN)	Factory-set GAIN	Manual GAIN adjustable via GAIN
2	E-shutter-speed (SHUT)	See shutter-speed table (Table 1)	
3			
4			
5	Video output mode (VIDEO)	1/60s non-interlace	1/120s interlace
6	Shutter mode (SMODE)	See shutter-mode table (Table 3)	
7			
8	Partial scan (PART)	See partial-scan table (Table 2)	
9			
0	RTS Exposure (EXP)	FIX mode	PULSE W mode

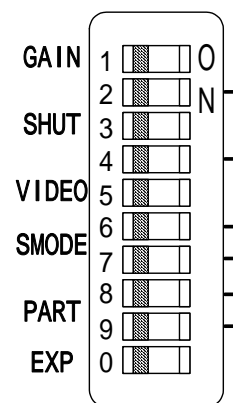

Notes: * Initial factory setting: All OFF

(Table 1) Electronic shutter-speed

Shutter-speed	No.2	No.3	No.4
OFF	OFF	OFF	OFF
1/200s	ON	OFF	OFF
1/500s	OFF	ON	OFF
1/1,000s	ON	ON	OFF
1/2,000s	OFF	OFF	ON
1/4,000s	ON	OFF	ON
1/8,000s	OFF	ON	ON
1/20,000s	ON	ON	ON

(Table 2) Partial-scan

Partial scan	No.8	No.9
OFF	OFF	OFF
Not acceptable	ON	OFF
1/2 partial	OFF	ON
1/4 partial	ON	ON

Notes : *Don't set Electronic shutter-speed in OFF under RTS mode.

(Table 3) Shutter-mode

Shutter mode		No.6	No.7	SYNC	
Random trigger	V reset	OFF	OFF	Internal sync	
	SYNC reset	ON	OFF		
	Non-reset	OFF	ON		
Not acceptable		ON	ON		
Random trigger	Non-reset (Multiple shutter)	OFF	OFF	Single VD	Ext. sync HD IN
	Non-reset	ON	OFF	Consecutive VD	
	V reset	OFF	ON	No VD	
Restart / Reset		ON	ON	Single VD	

Notes : * Under normal shutter mode partial-scan, set No.6,7 in OFF.

**Under PULSE W mode, SYNC reset is disabled.

(2)CCU rear-panel SW

Function	SW	Selected Function
Ext. SYNC IN impedance (HD/VD)	HIGH	HIGH impedance (Initial factory setting)
	75Ω	75Ω

[Relative Spectrum Response]

*Including lens characteristics, Excluding light source characteristics

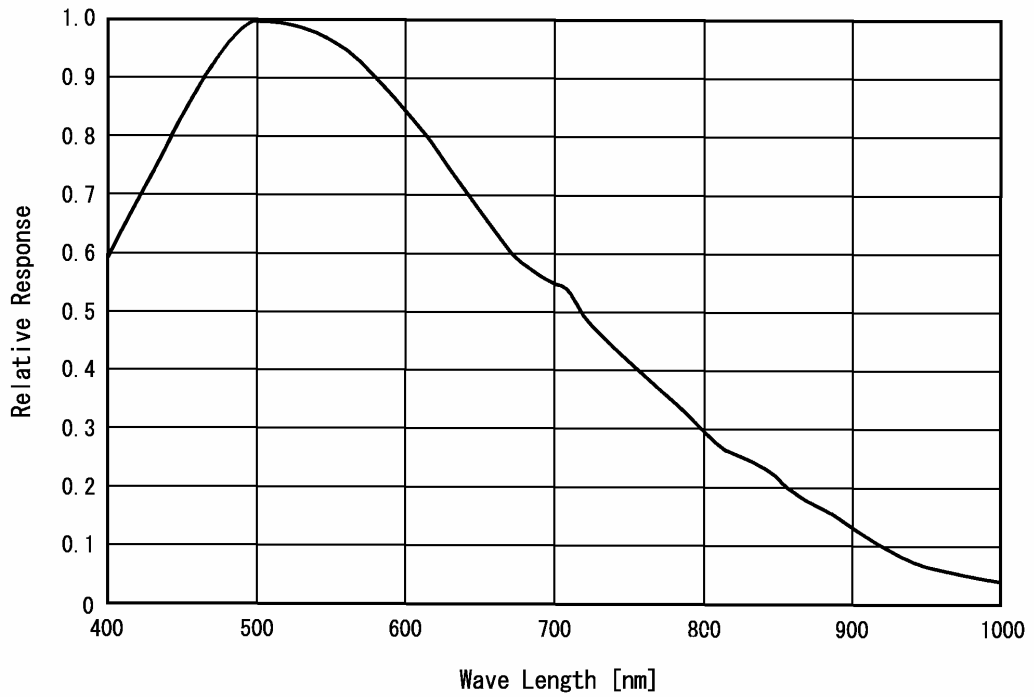

[Optical black characteristics]

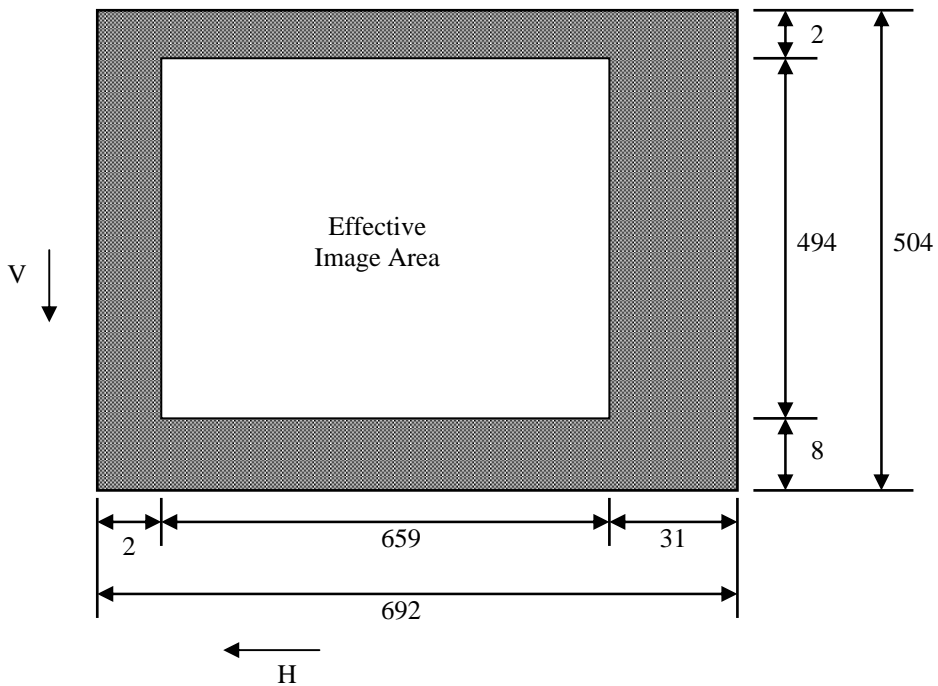

Device structure

Total pixels : 692(H) x 504(V)

Effective pixels : 659(H) x 494(V)

Optical black

Horizontal : 2pixels --- 31pixels

Vertical : 8pixels --- 2pixels

7. TIMING CHART

(1) H rate timing

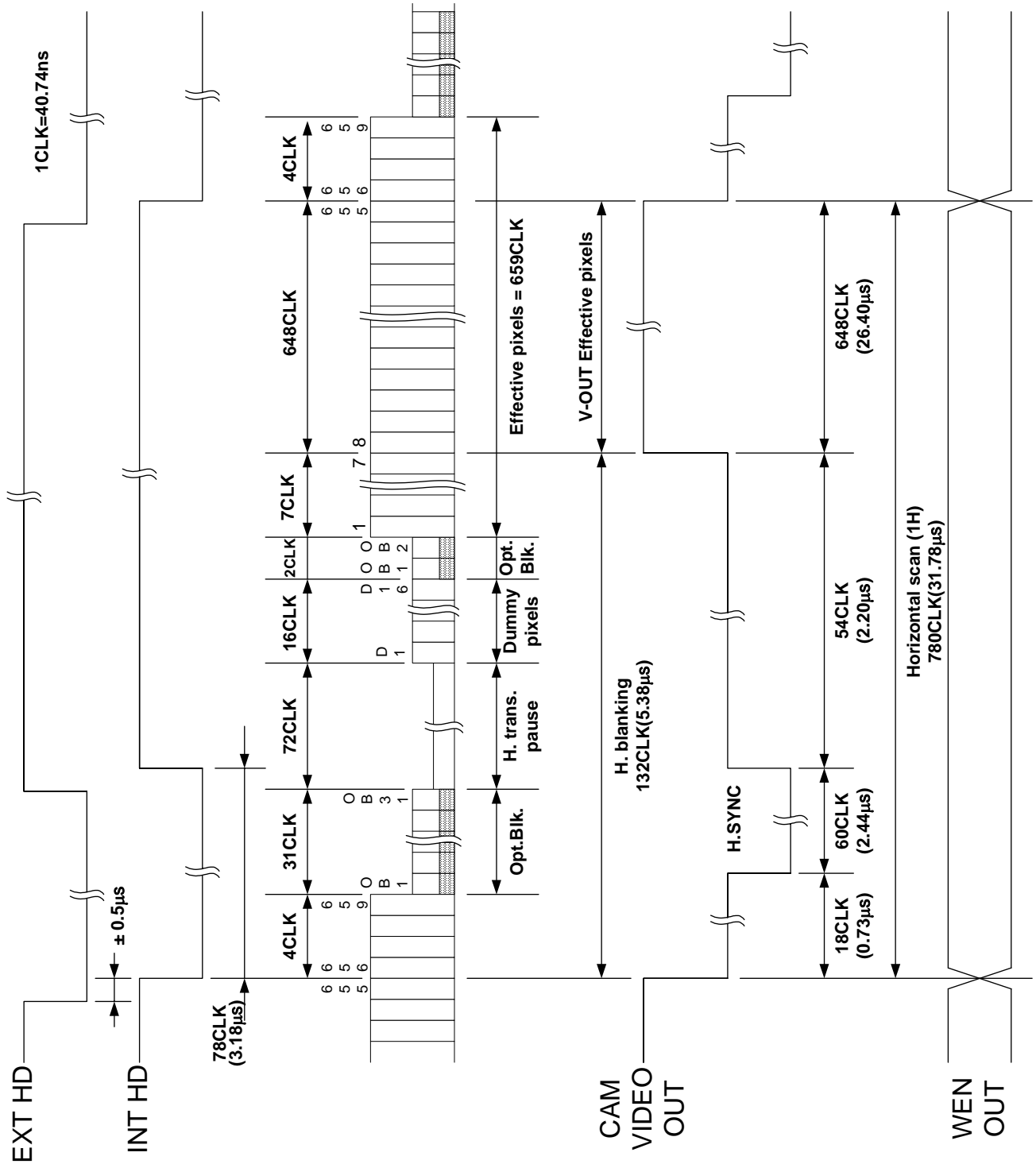

(2) 1/60s Non-interlace mode

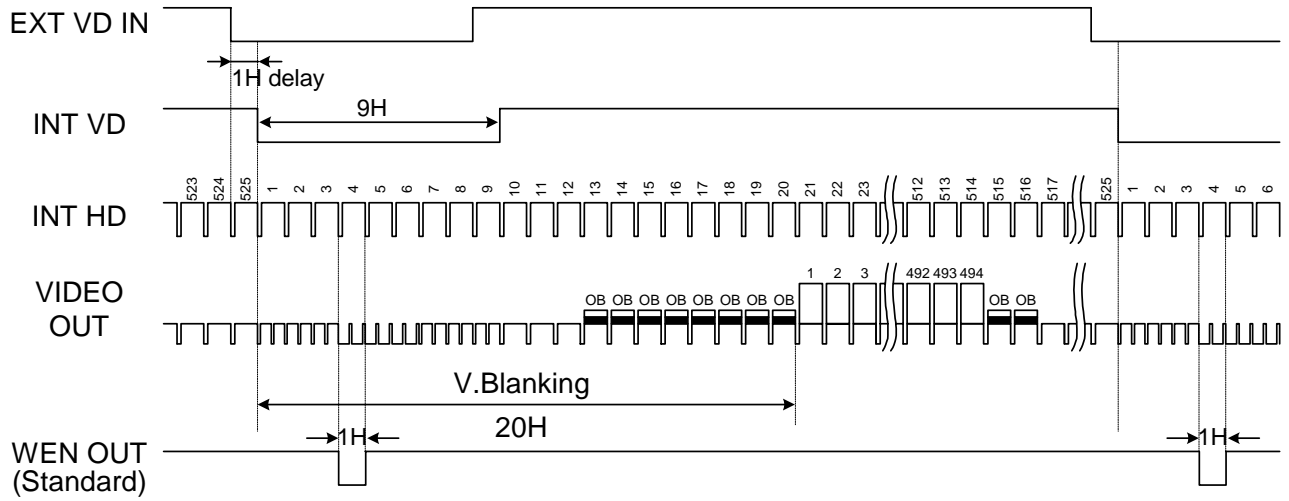

Ext. VD – Ext. HD phase difference

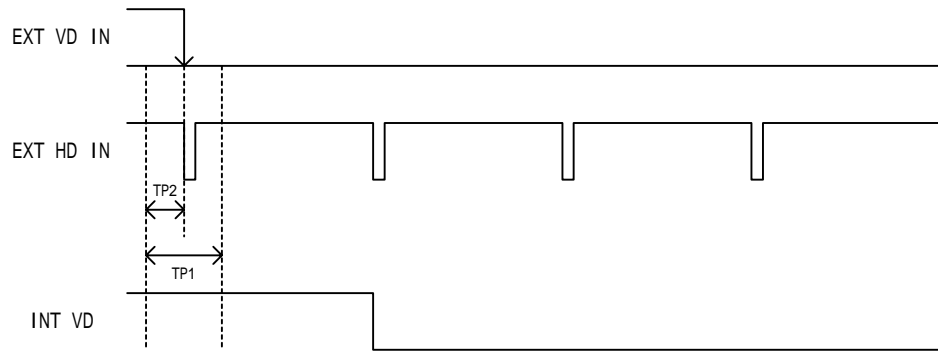

TP1 : 10.0 us
TP2 : 5.0 us

(3) 1/120s 2:1 Interlace mode

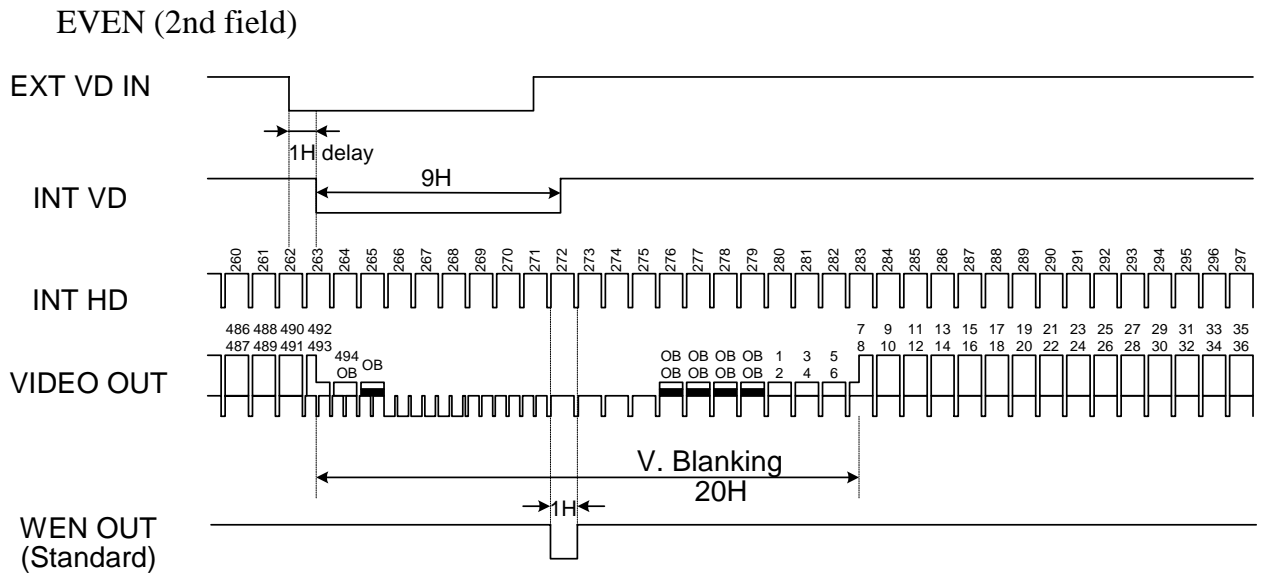
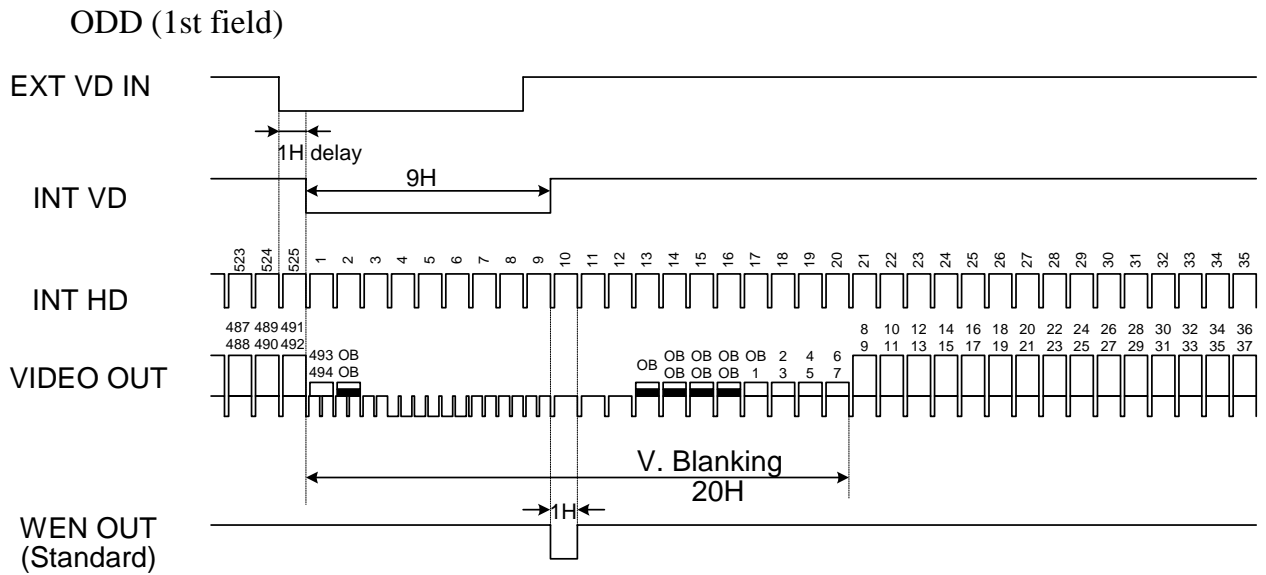

Ext. VD – Ext. HD phase difference

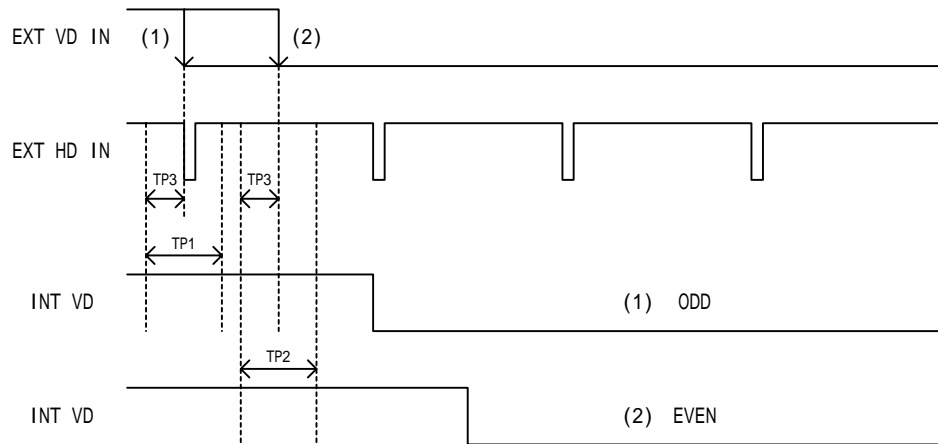

TP1 : ODD reset range 10.0 us
 TP2 : EVEN reset range 10.0 us
 TP3 : 5.0 us

(4) WEN timing
 (a) Normal shutter mode
 <1/60s Non interlace mode>

Under normal scan mode

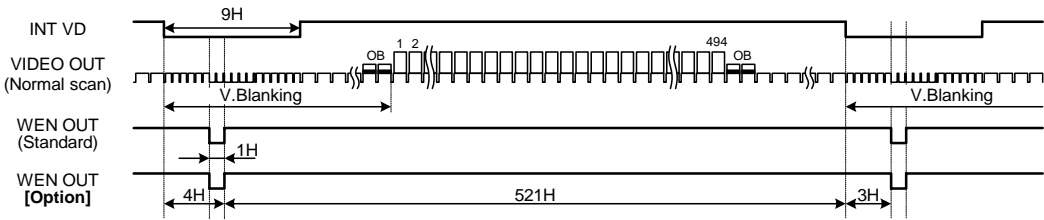

Under partial scan V-reset mode (Standard)

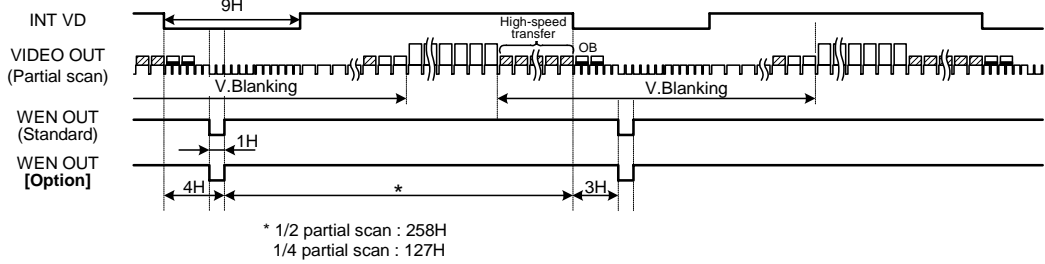

Under partial scan Non-reset mode [Option]

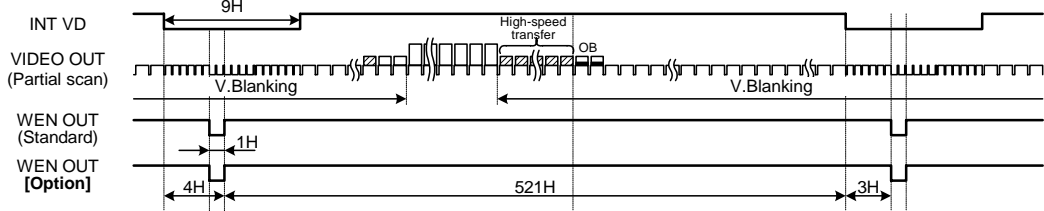

<1/120s Interlace mode ODD Field>

Under normal scan mode

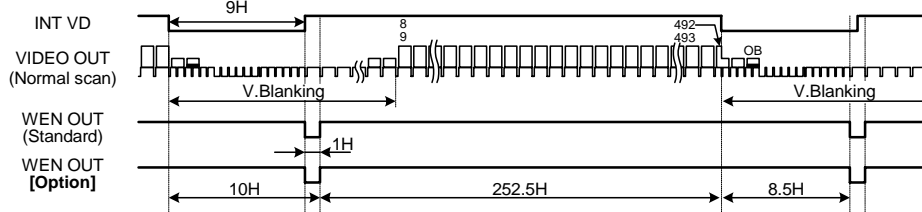

Under partial scan V-reset mode (Standard)

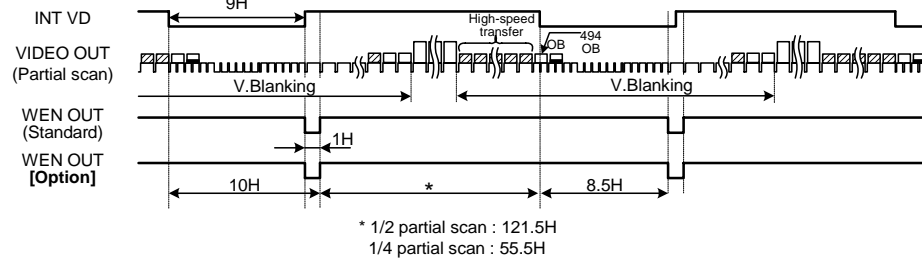

Under partial scan Non-reset mode [Option]

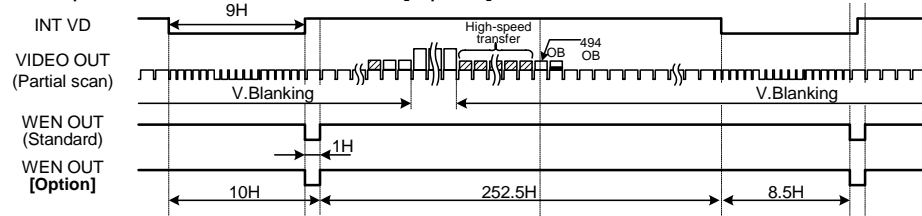

<1/120s Interlace mode EVEN Field>

Under normal scan mode

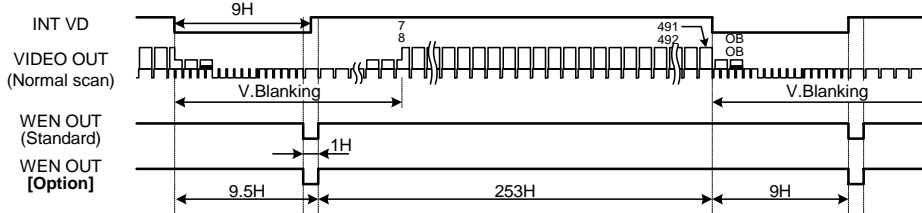

Under partial scan V-reset mode (Standard)

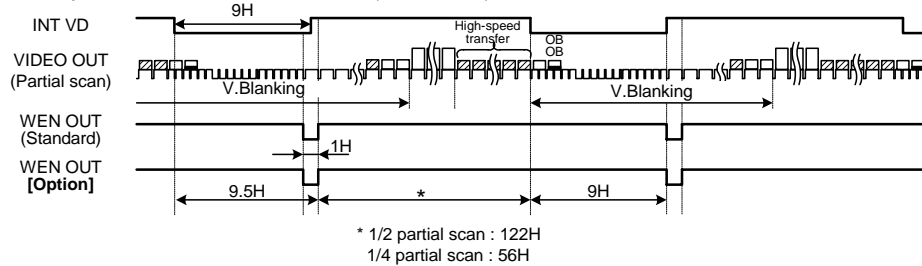

Under partial scan Non-reset mode [Option]

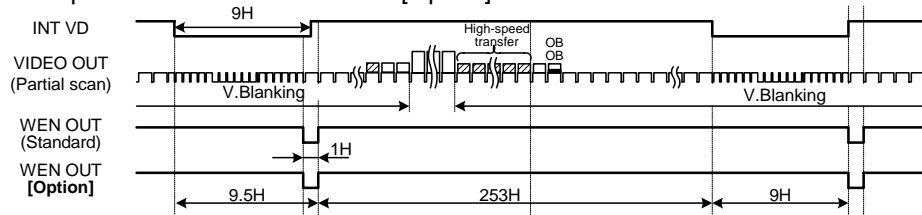

(b)RTS Non-reset mode (Consecutive VD)

<1/60s Non interlace mode>

Under normal scan mode

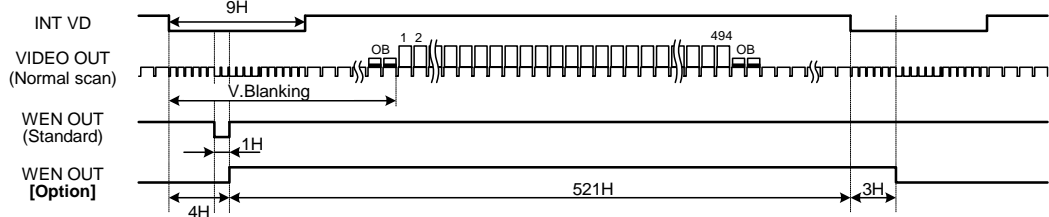

Under partial scan mode

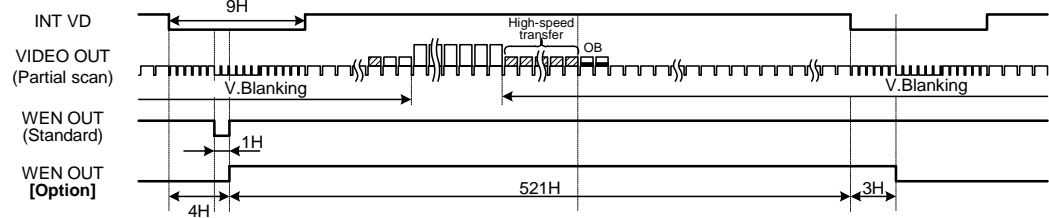

<1/120s Interlace mode ODD Field>

Under normal scan mode

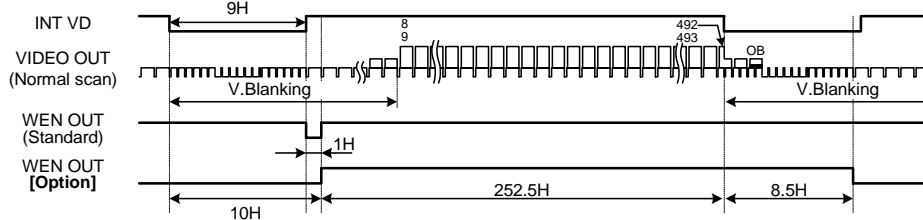

Under partial scan mode

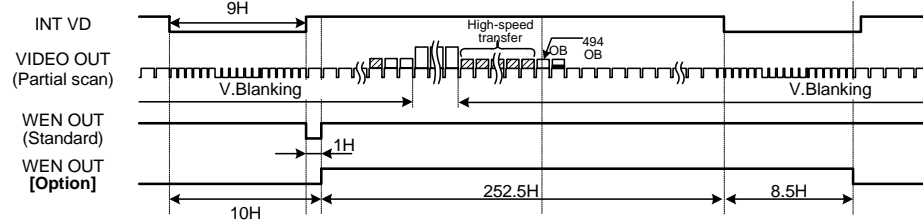

<1/120s Interlace mode EVEN Field>

Under normal scan mode

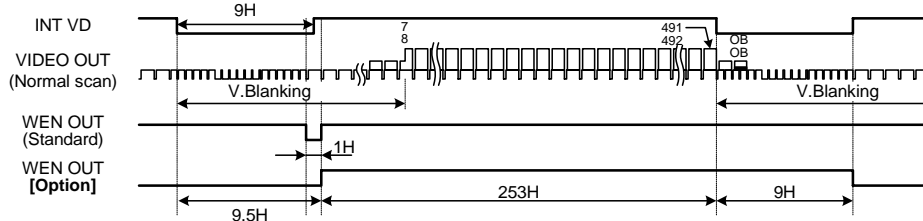

Under partial scan mode

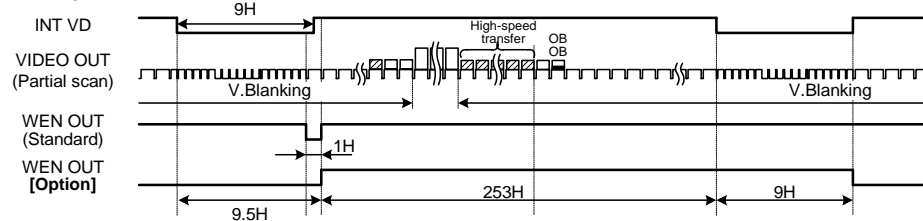

(c)RTS Non-reset mode (Single VD) / V-reset mode / SYNC-reset mode

<1/60s Non interlace mode>

Under normal scan mode

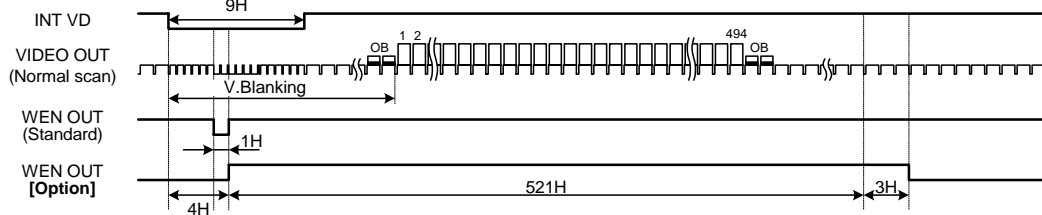

Under partial scan mode

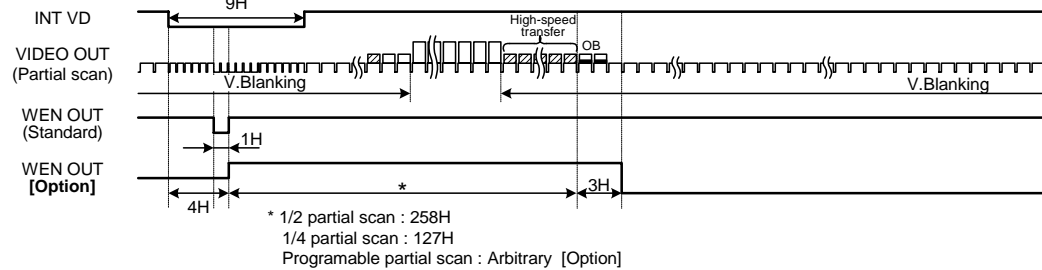

<1/120s Interlace mode ODD Field>

Under normal scan mode

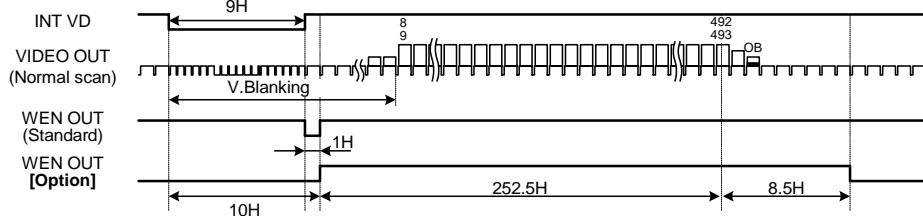

Under partial scan mode

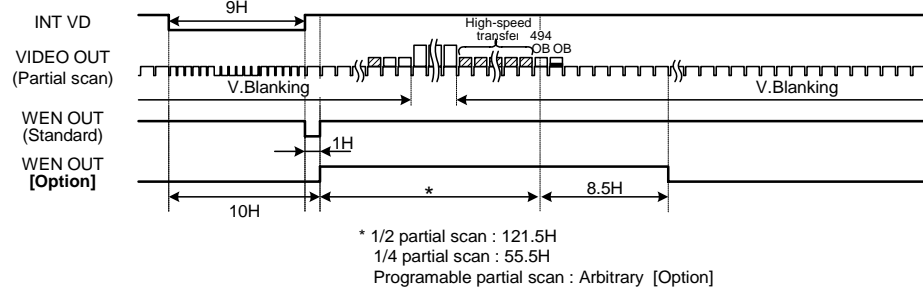

<1/120s Interlace mode EVEN Field>

*Under Non-reset mode (Single VD) only.

Under normal scan mode

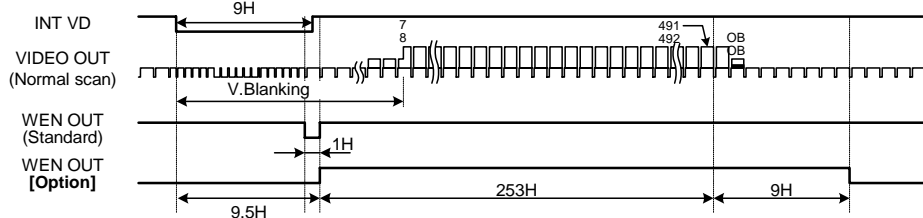

Under partial scan mode

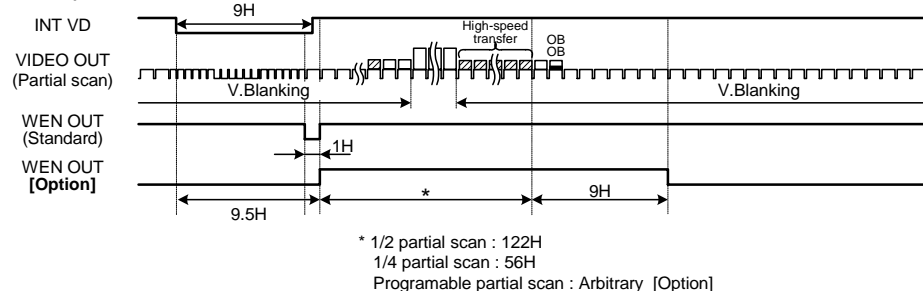

(d) Restart / reset mode

<1/60s Non interlace mode>

Under normal scan mode

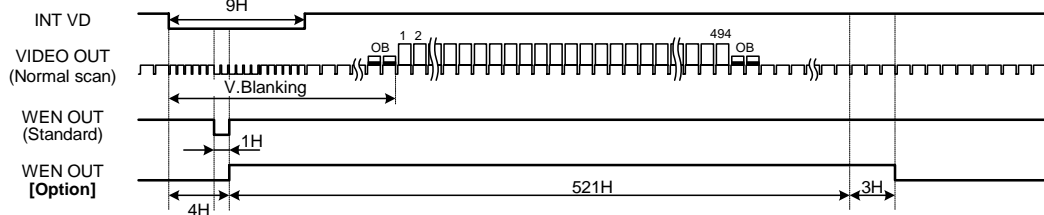

Under partial scan mode

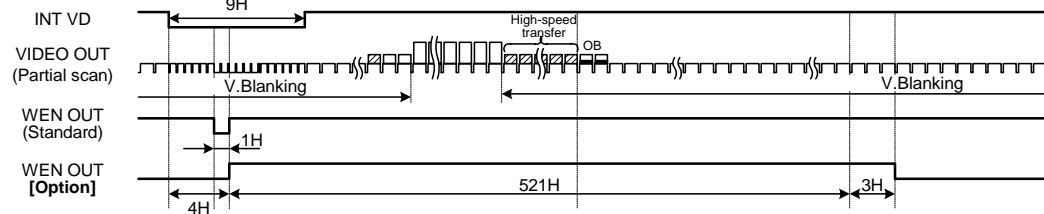

<1/120s Interlace mode ODD Field>

Under normal scan mode

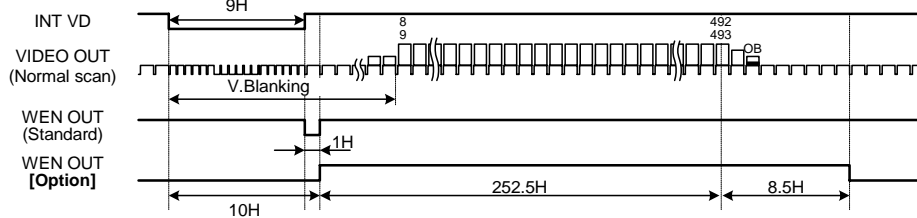

Under partial scan mode

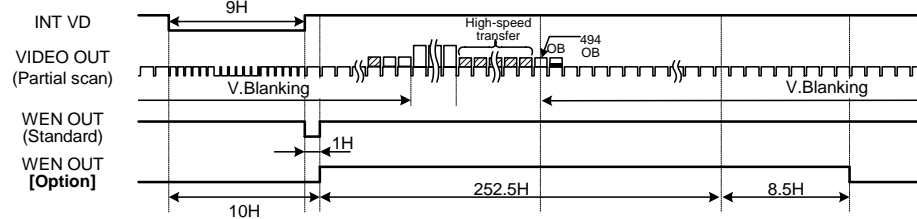

<1/120s Interlace mode EVEN Field>

Under normal scan mode

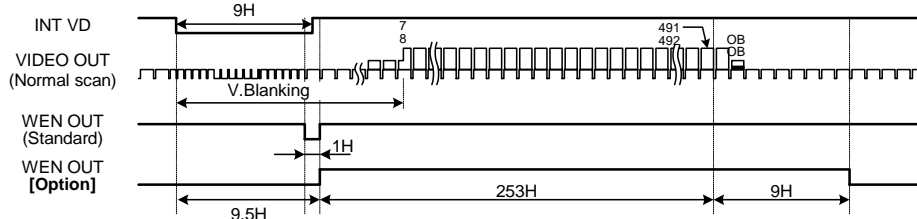

Under partial scan mode

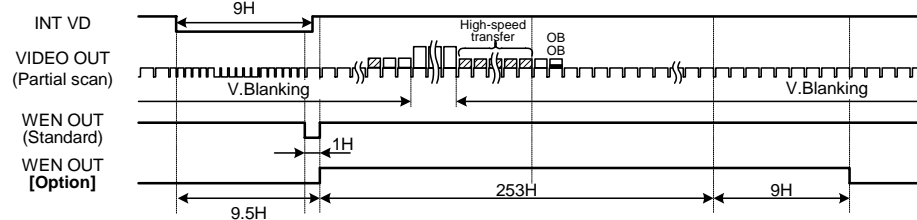

8. EXTERNAL-VIEW DRAWING

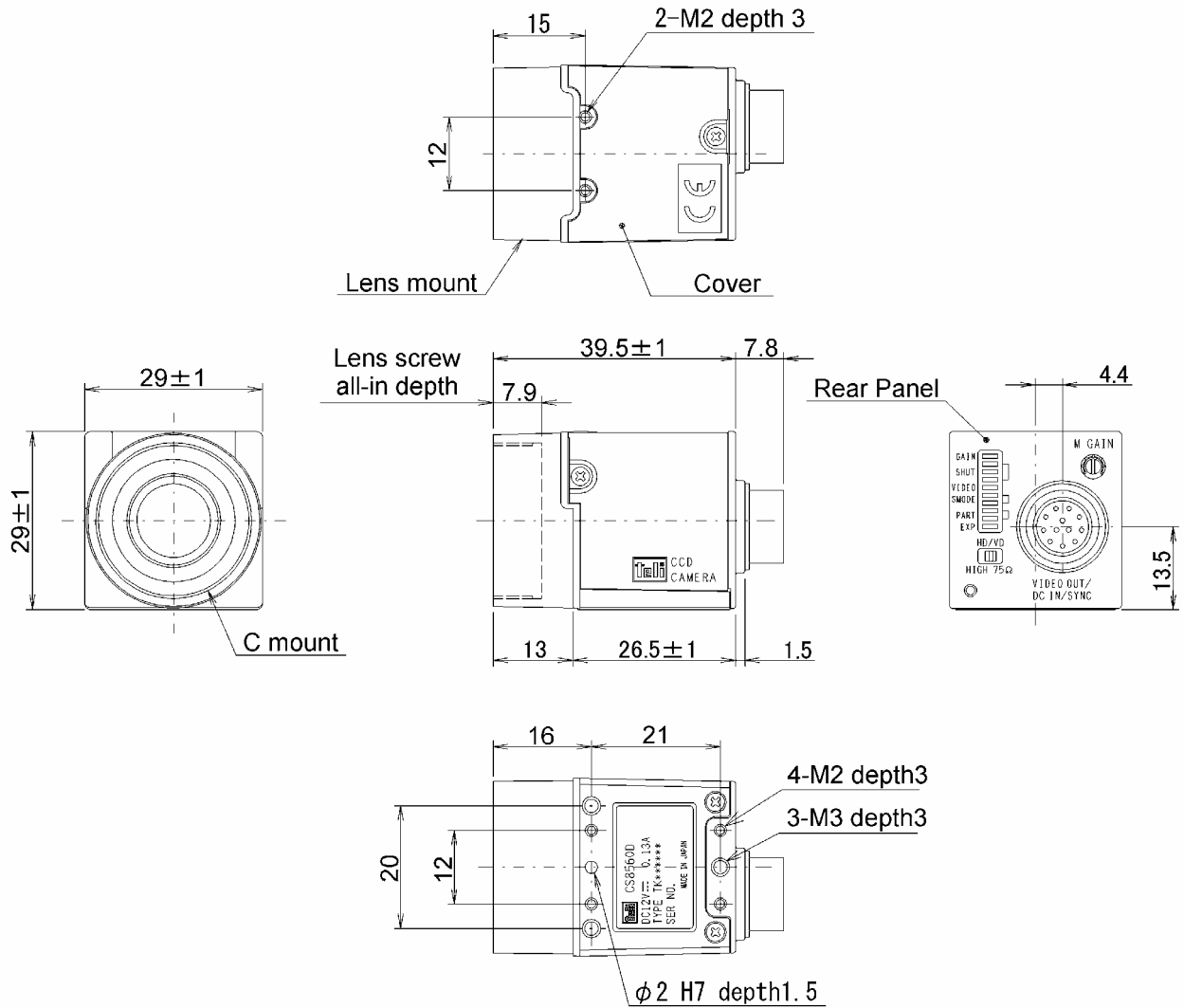

Specification

Material	Lens-mount , Rear panel	: Aluminum die-cast
	Cover	: Anticorrosion aluminum alloy
Processing	Lens-mount , Rear panel	: Cation coating (Black)
	Cover	: Leather satin coating (Black)



TOSHIBA TELI CORPORATION

Head Office: 7-1, 4 chome, Asahigaoka, Hino-shi, Tokyo, 191-0065, Japan
(Overseas Sales Department)
Phone: +81-42-589-8771 Fax: +81-42-589-8774

URL: <http://www.toshiba-teli.co.jp>

The design and specification is subject to change without notice.